

ZYRA

glass.

by gaviota



E **Manual de Instalación**

F *Manuel d'installation*

GB *Installation manual*

I *Manuel di installazione*



E Advertencias de seguridad **GB** Safety warnings **F** Avertissement de sécurité **I** Avvertence e note di sicurezza

- E**
 - Leer detenidamente estas instrucciones de montaje antes de cualquier uso y conservarlas después de la instalación.
 - Antes de proceder a la instalación, asegúrese de que cuenta con todas las piezas según el sistema elegido.
 - El no respetar las instrucciones de montaje, uso y especificaciones técnicas del artículo, así como excederse en los rangos de uso máximos especificados (pesos, etc....), significará la exclusión de la **Política de Garantía y de Servicio Postventa de Gaviota Group**.
 - Una correcta instalación es responsabilidad del instalador, quien deberá asesorarse sobre las fijaciones adecuadas según la superficie, garantizando el montaje y funcionamiento correctos.
 - La instalación debe realizarse respetando totalmente la normativa vigente en materia de seguridad laboral.
 - Verificar que no exista ningún obstáculo que cause algún impedimento para un uso adecuado y un correcto funcionamiento.
 - En el caso de precisar montaje de partes eléctricas, deben estar desconectadas de la tensión y se observará la normativa legal. las conexiones inadecuadas causan peligro.
 - En caso de productos motorizados, debe tenerse en cuenta que el motor incorpora un dispositivo de seguridad térmica para evitar sobrecalentamientos y averías. Este dispositivo se pone en marcha cuando se pulsan insistentemente y sin aparente necesidad los inversores de accionamiento.
 - Es recomendable realizar una limpieza y mantenimiento periódico, sin productos abrasivos. Para ello se debería contactar con un servicio especializado de mantenimiento.
 - En caso de precisar anclajes a pared, respetar las posiciones especificadas para los soportes pared y el N.º de tornillos a colocar en cada uno de ellos.
 - Las configuraciones propuestas son adecuadas para hormigón B25. Los elementos de sujeción y la obra deben soportar la tracción mínima especificada. Verificar con el fabricante.
 - Las imágenes mostradas son orientativas y pueden diferir de la realidad.
- GB**
 - Read these assembly instructions carefully before any use and keep them after installation.
 - Before proceeding with the installation, ensure you have all the parts according to the chosen system.
 - Failure to comply with the assembly instructions, usage guidelines, and technical specifications of the product, or exceeding the specified maximum operating ranges (weights, etc.) will result in the exclusion of the **Gaviota Group Warranty and After-Sales Service Policy**.
 - Proper installation is the responsibility of the installer, who must seek advice on suitable fixings depending on the surface, ensuring correct assembly and operation.
 - The installation must be carried out in full compliance with current occupational safety regulations.
 - Check that there are no obstacles that could impede proper use and correct operation.
 - If electrical parts require installation, they must be disconnected from the power supply, and legal regulations must be observed. Improper connections pose a danger.
 - For motorised products, note that the motor includes a thermal safety device to prevent overheating and damage. This device is activated if the drive controls are pressed repeatedly and unnecessarily.
 - It is recommended to carry out periodic cleaning and maintenance without abrasive products. For this, a specialised maintenance service should be contacted.
 - If wall anchors are required, respect the specified positions for the wall brackets and the number of screws to be installed in each of them.
 - The proposed configurations are suitable for B25 concrete. The fixings and structure must withstand the specified minimum traction force. Check with the manufacturer.
 - The images shown are indicative and may differ from reality.
- F**
 - Lire attentivement ces instructions de montage avant toute utilisation et les conserver après l'installation.
 - Avant de procéder à l'installation, assurez-vous de disposer de toutes les pièces conformément au système choisi.
 - Le non-respect des instructions de montage, des consignes d'utilisation et des spécifications techniques de l'article, ainsi que le dépassement des plages d'utilisation maximales spécifiées (poids, etc.) entraînera l'exclusion de la **Politique de Garantie et de Service Après-Vente de Gaviota Group**.
 - Une installation correcte relève de la responsabilité de l'installateur, qui devra s'informer sur les fixations appropriées selon la surface, garantissant ainsi un montage et un fonctionnement corrects.
 - L'installation doit être réalisée dans le strict respect de la réglementation en vigueur en matière de sécurité au travail.
 - Vérifiez qu'il n'y a pas d'obstacle susceptible d'entraver une utilisation appropriée et un bon fonctionnement.
 - En cas de montage de composants électriques, ceux-ci doivent être déconnectés de l'alimentation, et la réglementation légale doit être respectée. Les connexions incorrectes sont dangereuses.
 - Pour les produits motorisés, il convient de noter que le moteur est équipé d'un dispositif de sécurité thermique pour éviter les surchauffes et les pannes. Ce dispositif s'active lorsque les inverseurs de commande sont actionnés de manière répétée et sans nécessité apparente.
 - Il est recommandé d'effectuer un nettoyage et un entretien périodiques sans produits abrasifs. Pour cela, il convient de contacter un service de maintenance spécialisé.
 - En cas de fixation murale, respectez les positions spécifiées pour les supports muraux et le nombre de vis à installer dans chacun d'eux.
 - Les configurations proposées sont adaptées au béton B25. Les fixations et la structure doivent supporter la traction minimale spécifiée. Vérifiez auprès du fabricant.
 - Les images présentées sont à titre indicatif et peuvent différer de la réalité.
- I**
 - Leggere attentamente queste istruzioni di montaggio prima di qualsiasi utilizzo e conservarle dopo l'installazione.
 - Prima di procedere con l'installazione, assicurarsi di avere tutti i componenti in base al sistema scelto.
 - Il mancato rispetto delle istruzioni di montaggio, delle indicazioni d'uso e delle specifiche tecniche dell'articolo, così come il superamento delle gamme di utilizzo massime specificate (pesi, ecc.), comporterà l'esclusione dalla **Politica di Garanzia e di Assistenza Post-Vendita di Gaviota Group**.
 - Una corretta installazione è responsabilità dell'installatore, il quale deve informarsi sui fissaggi adeguati in base alla superficie, garantendo il corretto montaggio e funzionamento.
 - L'installazione deve essere eseguita nel pieno rispetto delle normative vigenti in materia di sicurezza sul lavoro.
 - Verificare che non ci siano ostacoli che possano impedire un uso adeguato e un corretto funzionamento.
 - Se è necessario installare componenti elettrici, questi devono essere scollegati dalla tensione e devono essere rispettate le normative legali. Connessioni errate possono essere pericolose.
 - Per i prodotti motorizzati, tenere presente che il motore è dotato di un dispositivo di sicurezza termica per evitare surriscaldamenti e guasti. Questo dispositivo si attiva quando gli interruttori di comando vengono azionati insistentemente e senza necessità apparente.
 - Si consiglia di effettuare una pulizia e una manutenzione periodiche senza prodotti abrasivi. A tal fine, è opportuno contattare un servizio di manutenzione specializzato.
 - Se sono necessari ancoraggi a parete, rispettare le posizioni specificate per i supporti a parete e il numero di viti da installare in ciascuno di essi.
 - Le configurazioni proposte sono adatte per calcestruzzo B25. Gli elementi di fissaggio e la struttura devono sopportare la trazione minima specificata. Verificare con il produttore.
 - Le immagini mostrate sono indicative e possono differire dalla realtà.

Leyenda de símbolos y abreviaturas • *Leyenda de símbolos y abreviaturas*
Leyenda de símbolos y abreviaturas • *Leyenda de símbolos y abreviaturas*



¡Precaución! • *Caution!*
Attention! • *Attenzione!*



Atención a este paso, es importante
Pay attention to this step, it's important
Soyez attentif à cette étape, c'est important
Prestare attenzione a questo passaggio, è importante



No apretar • *Do not tighten*
Ne pas serrer • *Non stringere*



Izquierda • *Left*
Gauche • *Sinistra*



Derecha • *Right*
Droite • *Destra*

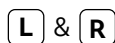

A izquierda y Derecha • *Left and Right*
Gauche et droite • *Sinistra e Destra*

Índice • *Index* • *Index* • *Indice*

01 **Especificaciones del sistema** • *System Specifications*
Spécifications du système • *Specifiche del sistema*

01.1 **Identificación de piezas** • *Parts identification*
Identification des pièces • *Identificazione dei pezzi*

01.2 **Componentes del sistema** • *System components*
Composants du système • *Componenti del sistema*

02 **Instalación en ubicación final** • *Installation at final location*
Installation sur le site final • *Installazione nella sede finale*

01 Especificaciones del sistema • System Specifications Spécifications du système • Specifiche del sistema

01.1 Identificación de piezas • Parts identification Identification des pièces • Identificazione dei pezzi

Perfil compensador exterior lateral
External lateral compensator profile
Profil compensateur latéral extérieur
Profilo compensatore laterale esterno

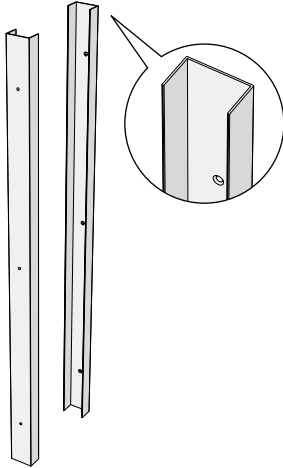

Perfil compensador superior • Upper compensator profile
Profil compensateur supérieur • Profilo compensatore superiore

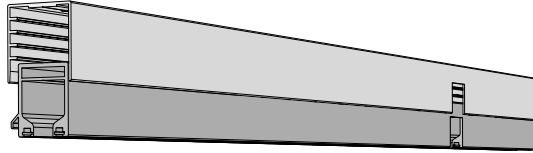

Perfil marco superior • Upper frame profile
Profil cadre supérieur • Profilo telaio superiore

Perfil compensador interior lateral
Internal lateral compensator profile
Profil compensateur latéral intérieur
Profilo compensatore laterale interno

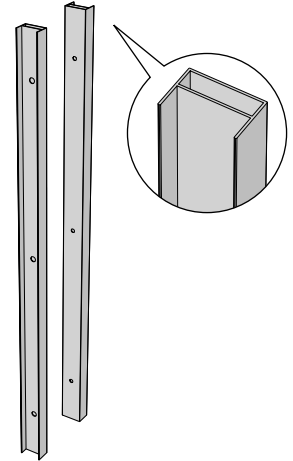

1ª Hoja • First panel • Première feuille • Prima anta

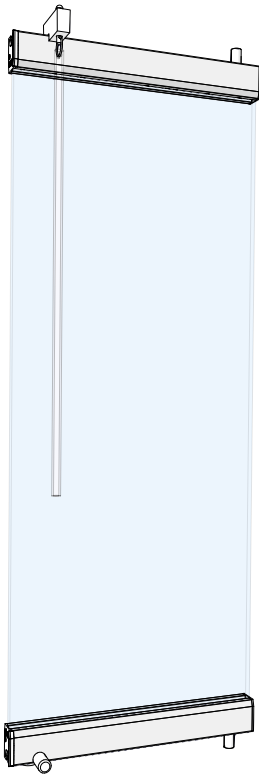

Hoja intermedia • Intermediate panel
Feuille intermédiaire • Anta intermedia

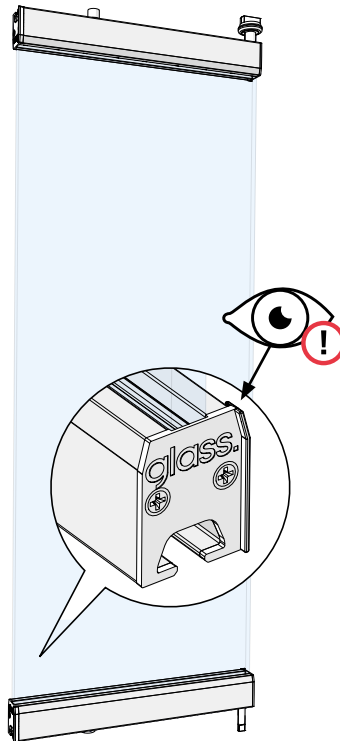

Hoja final • Final panel
Feuille finale • Anta finale

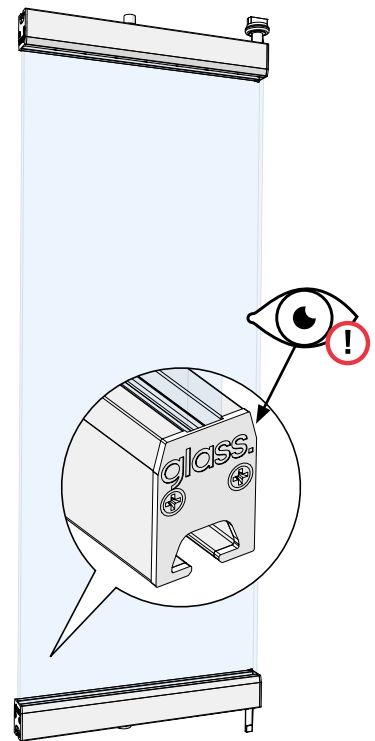

Perfil marco inferior • Lower frame profile
Profil cadre inférieur • Profilo telaio inferiore

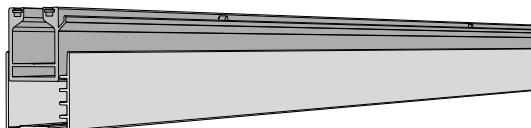

Perfil compensador inferior • Lower compensator profile
Profil compensateur inférieur • Profilo compensatore inferiore

01.2 Componentes del sistema • System components Composants du système • Componenti del sistema

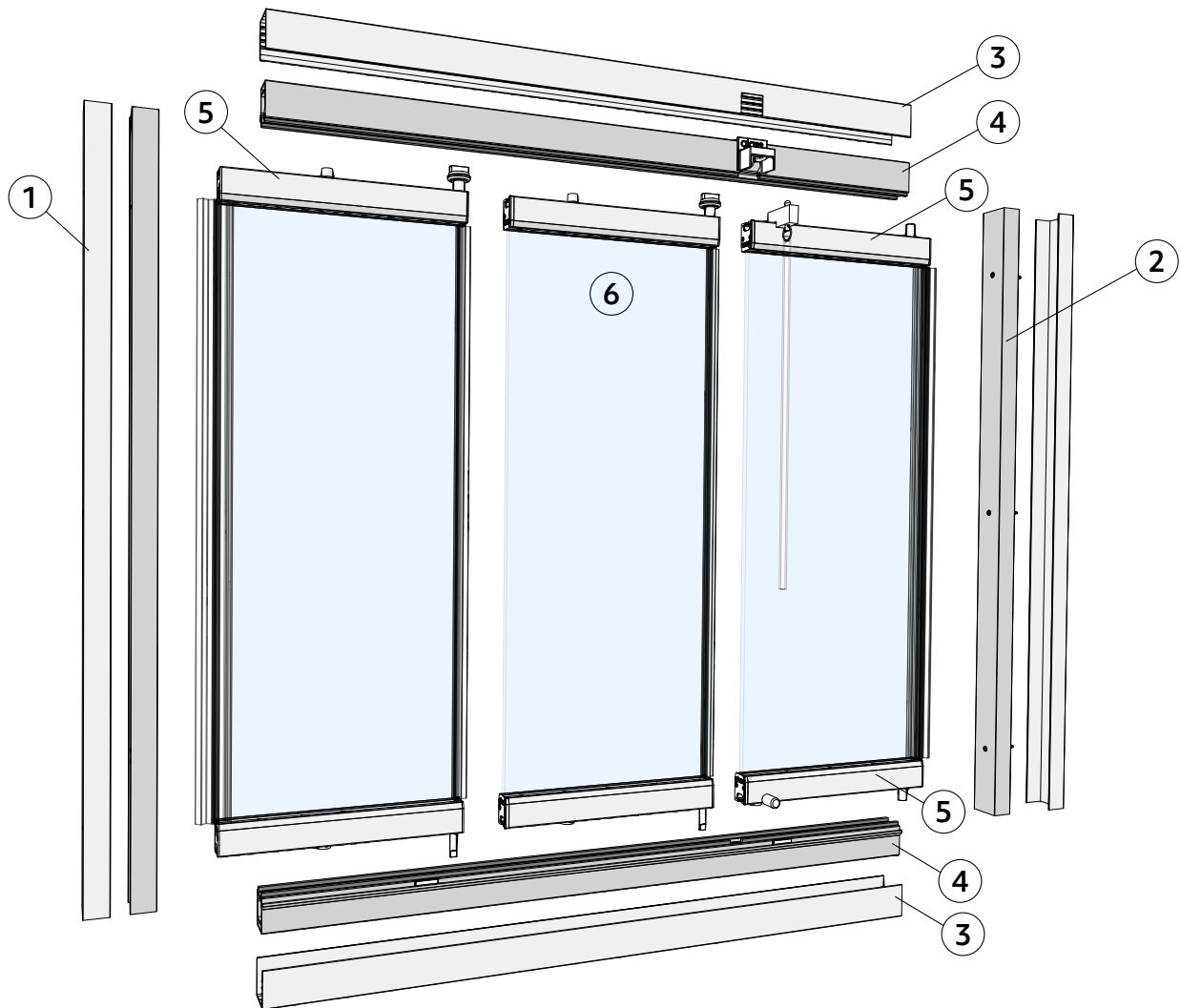

	Descripción • Description • Description • Descrizione
1	Perfil compensador exterior lateral • External lateral compensator profile Profil compensateur latéral extérieur • Profilo compensatore laterale esterno
2	Perfil compensador interior lateral • Internal lateral compensator profile Profil compensateur latéral intérieur • Profilo compensatore laterale interno
3	Perfil compensador • Compensator profile • Profil compensateur • Profilo compensatore
4	Perfil marco • Frame profile • Profil cadre • Profilo telaio
5	Perfil hoja • Panel profile • Profil feuille • Profilo anta
6	Vidrio • Glass • Verre • Vetro

02 **Instalación en ubicación final** • *Installation at final location*
Installation sur le site final • *Installazione nella sede finale*

1.

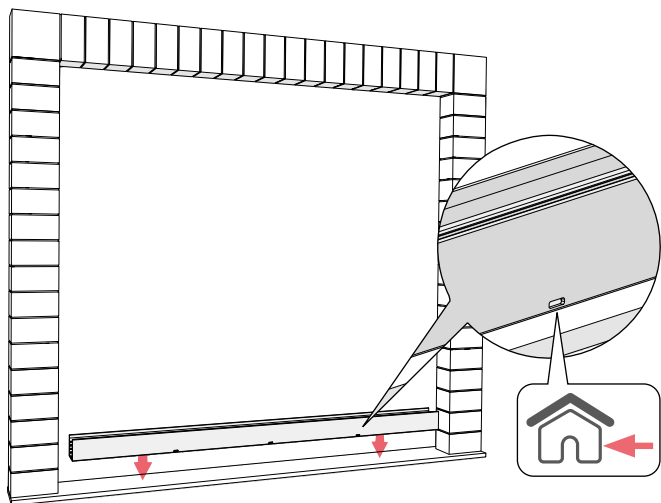

2.

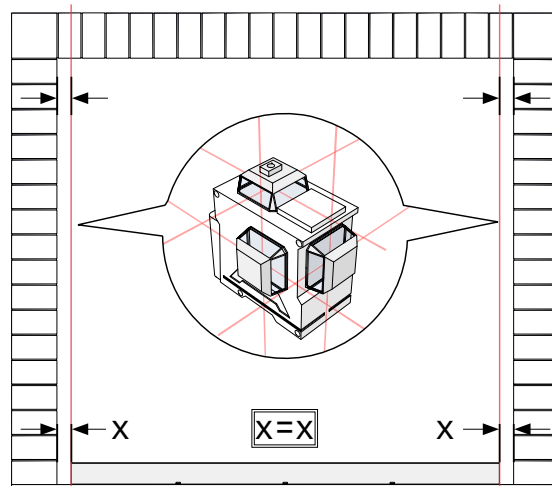

3.

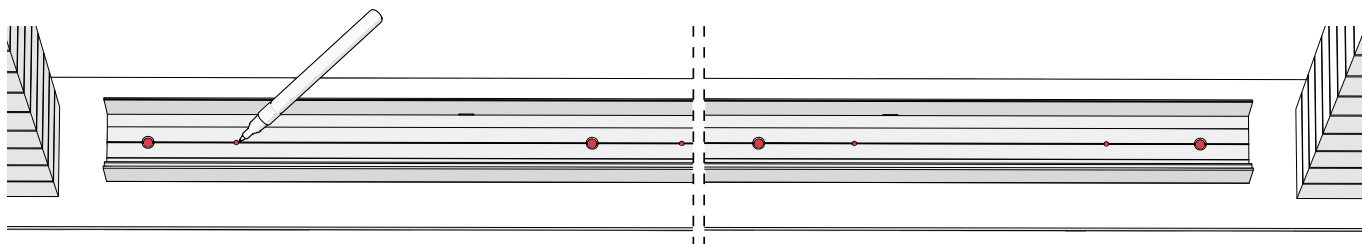

4a.

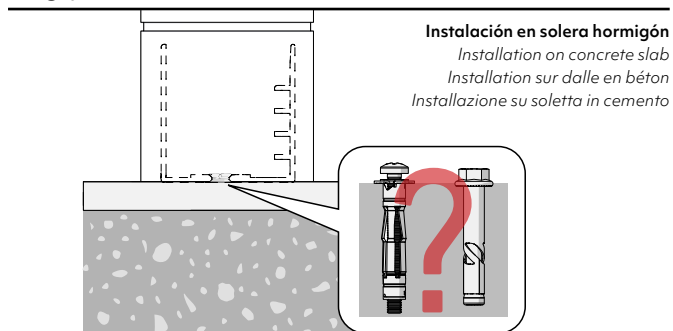

4b.

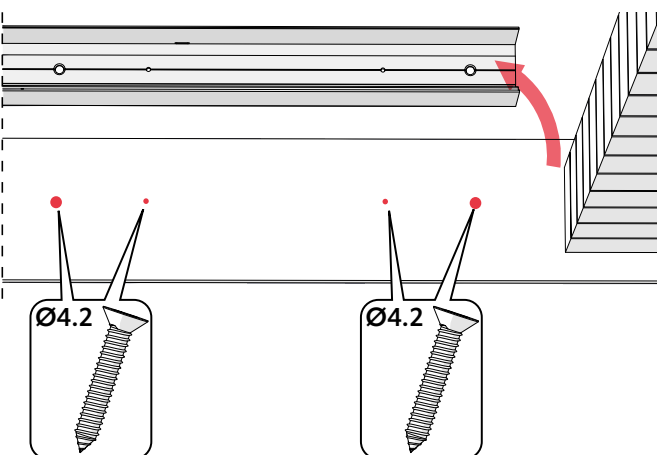
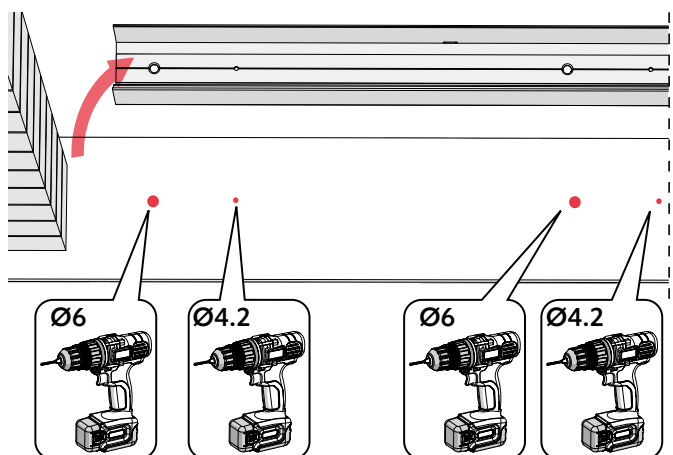
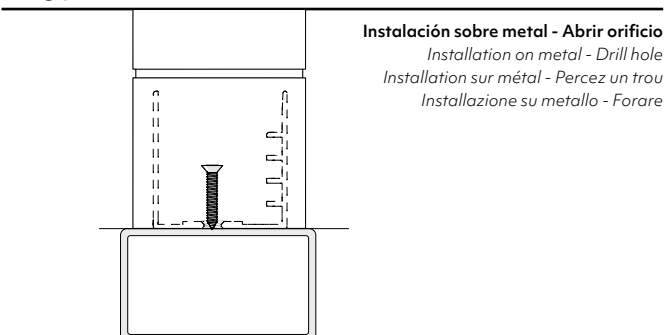

5.

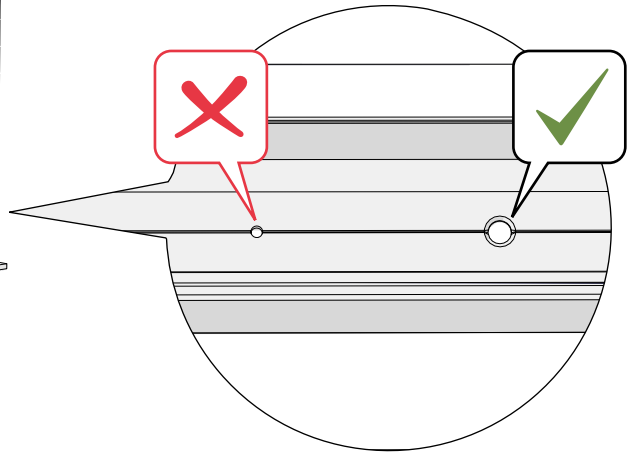
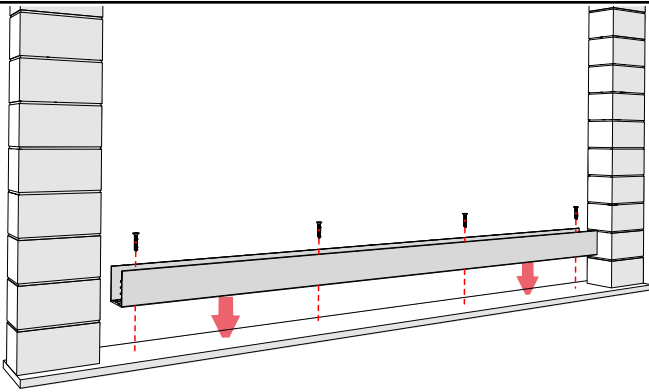

6.

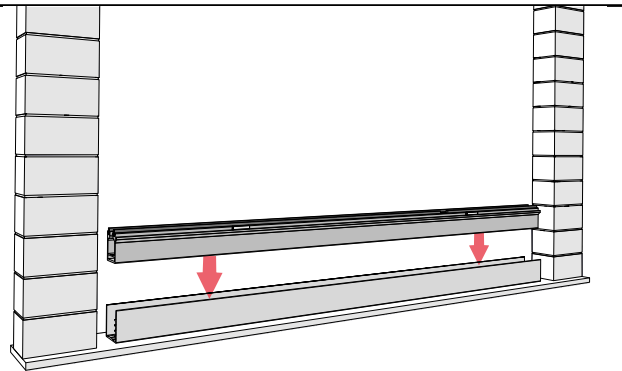

7.

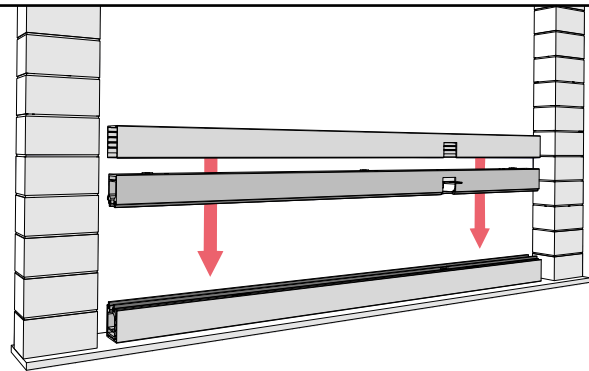

8.

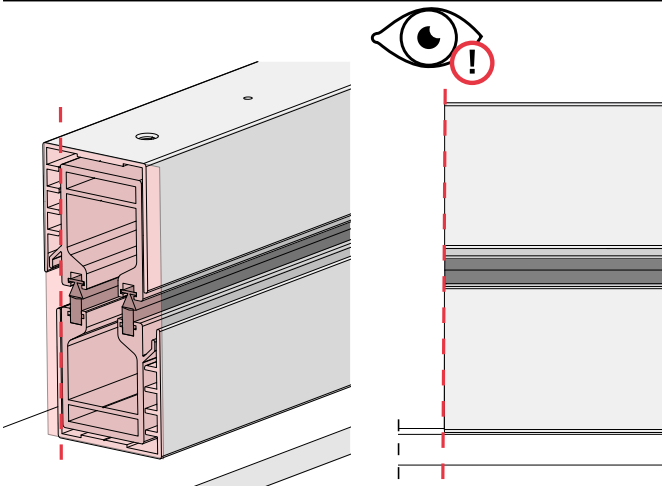

9.

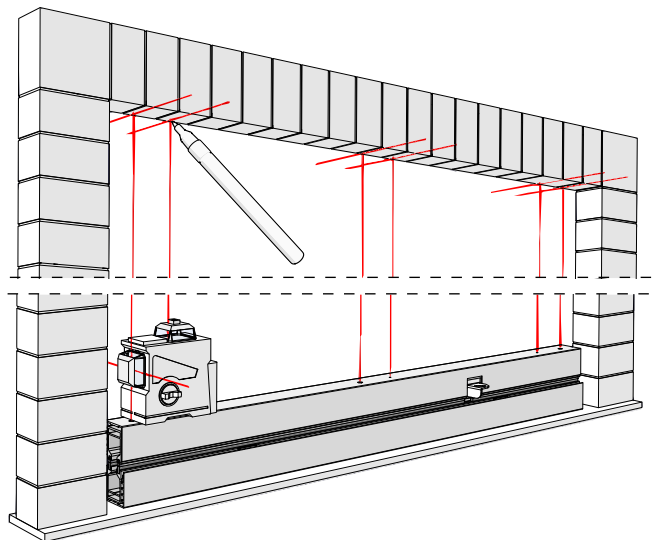

10a.

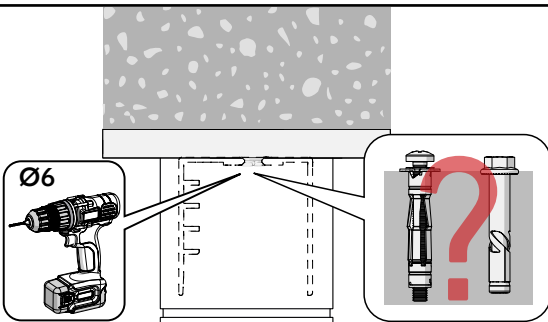

10b.

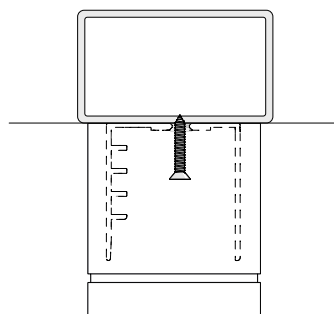

Instalación sobre metal - Abrir orificio
Installation on metal - Drill hole
Installation sur métal - Percez un trou
Installazione su metallo - Forare

11.

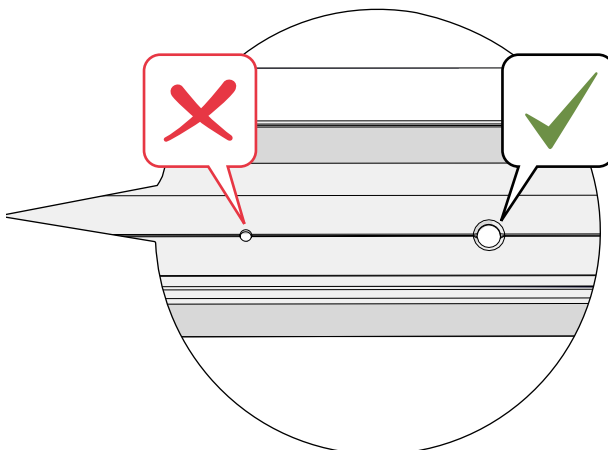
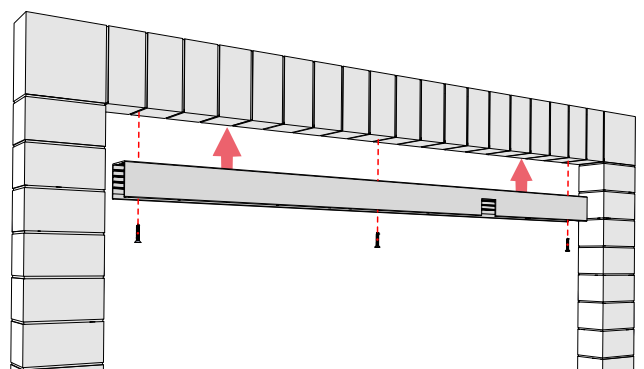

12.

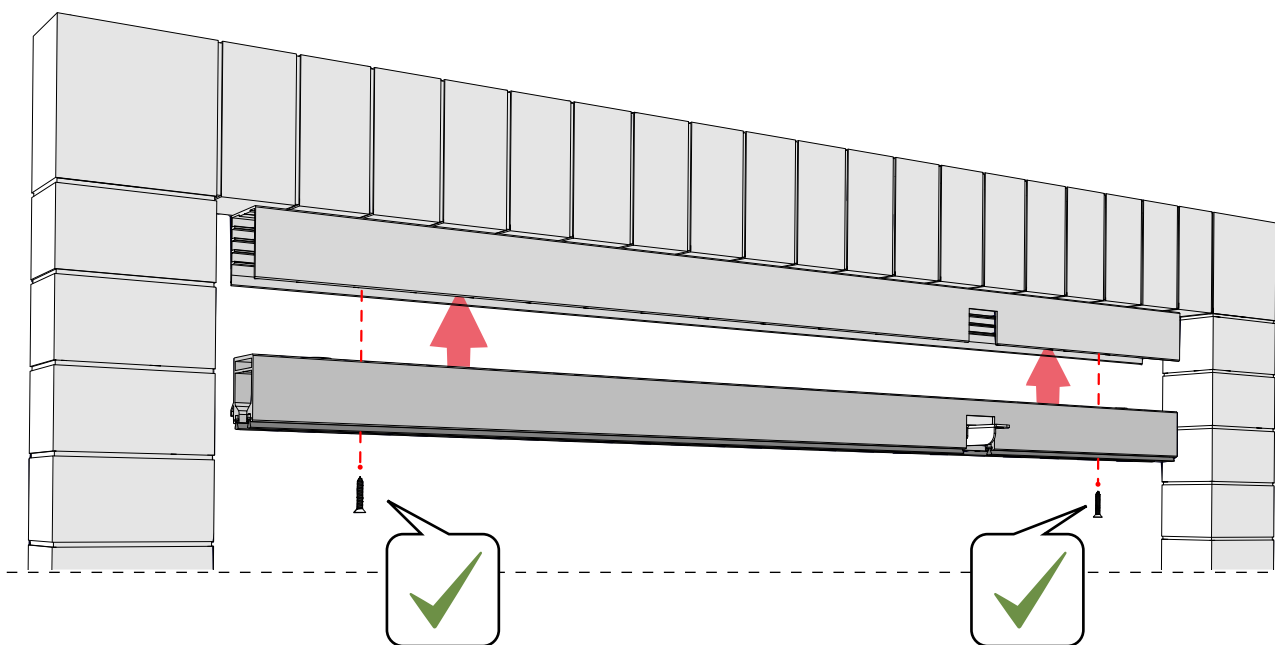

13.

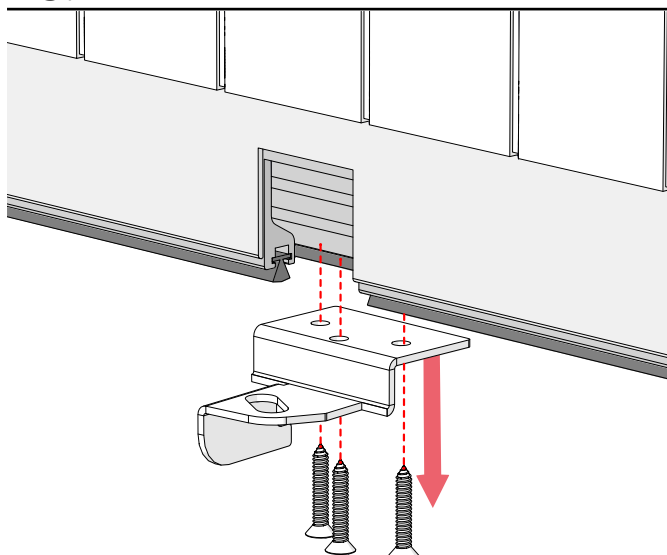

14.

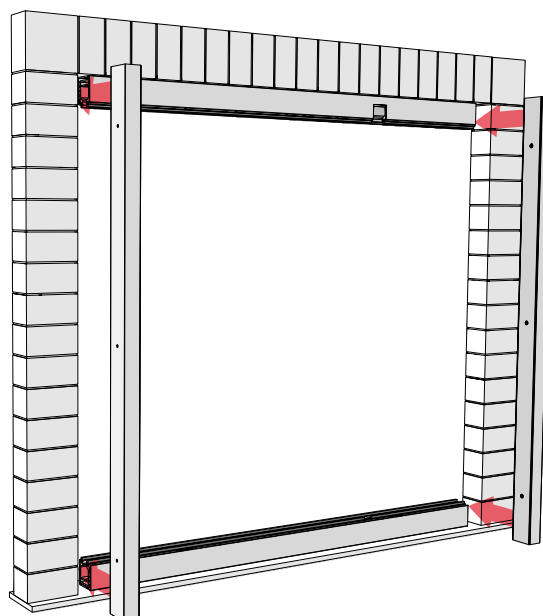

15.

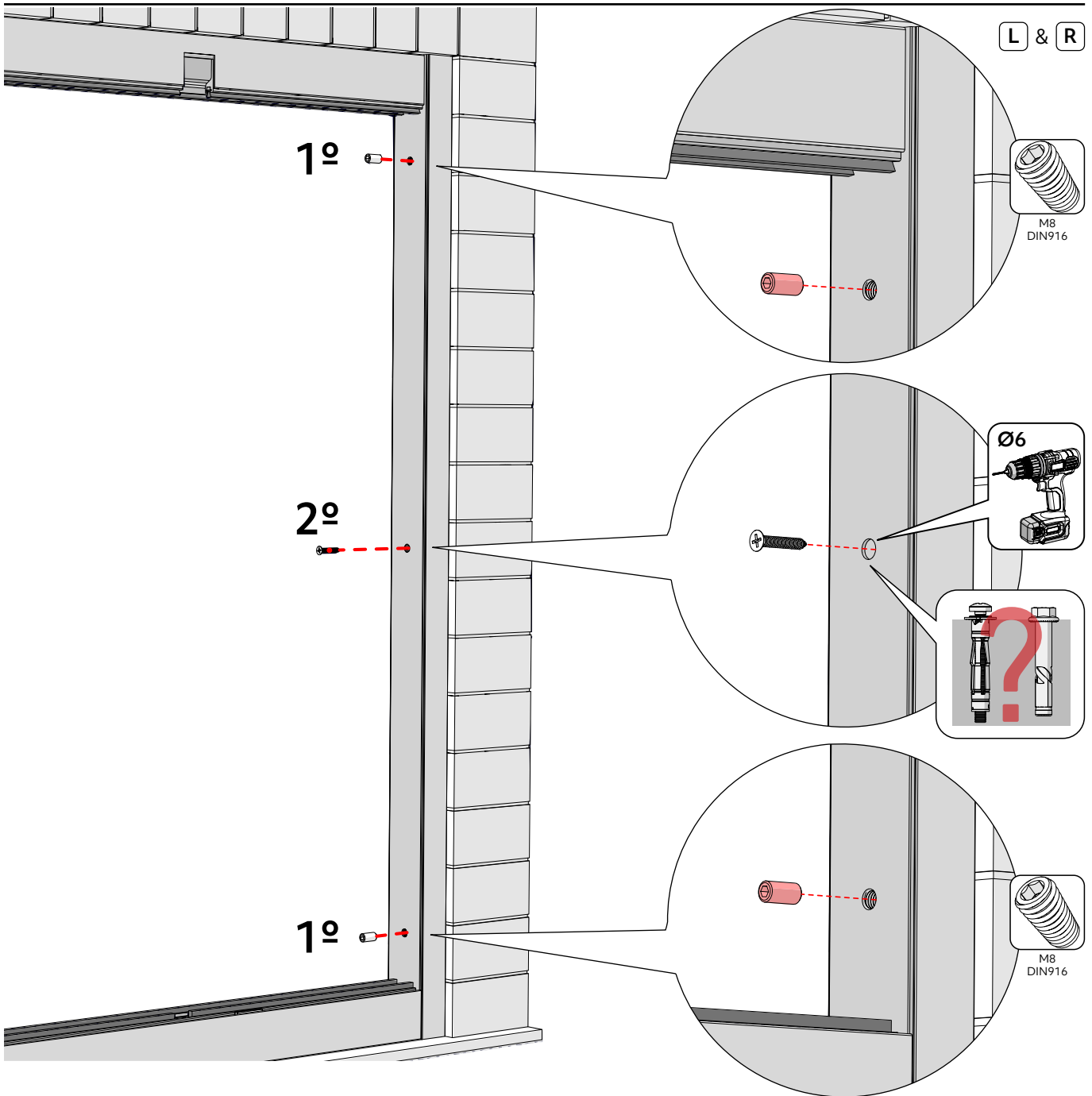

16.

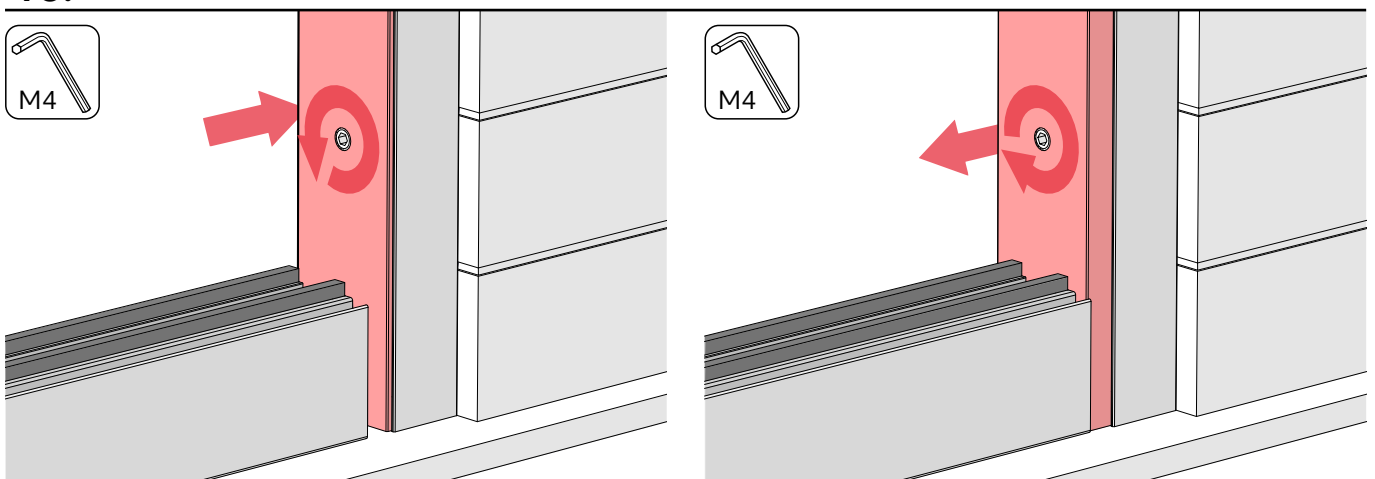

17.

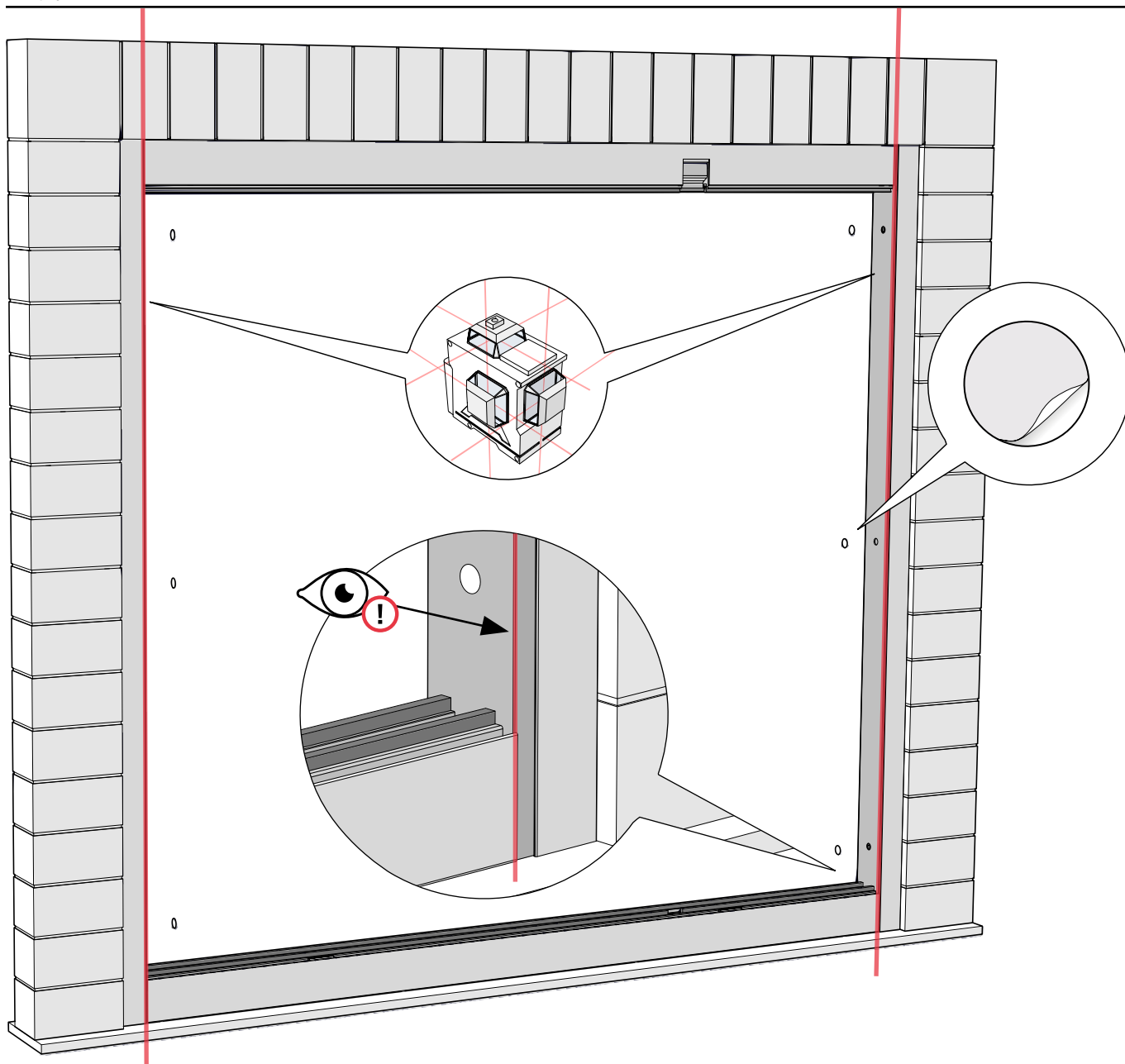

18.

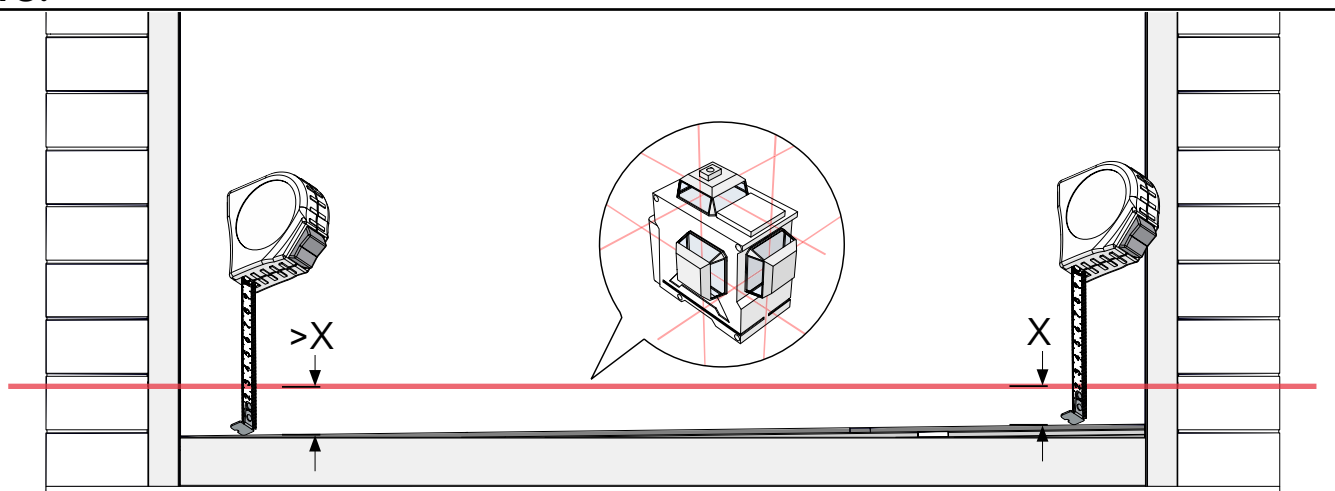

19.

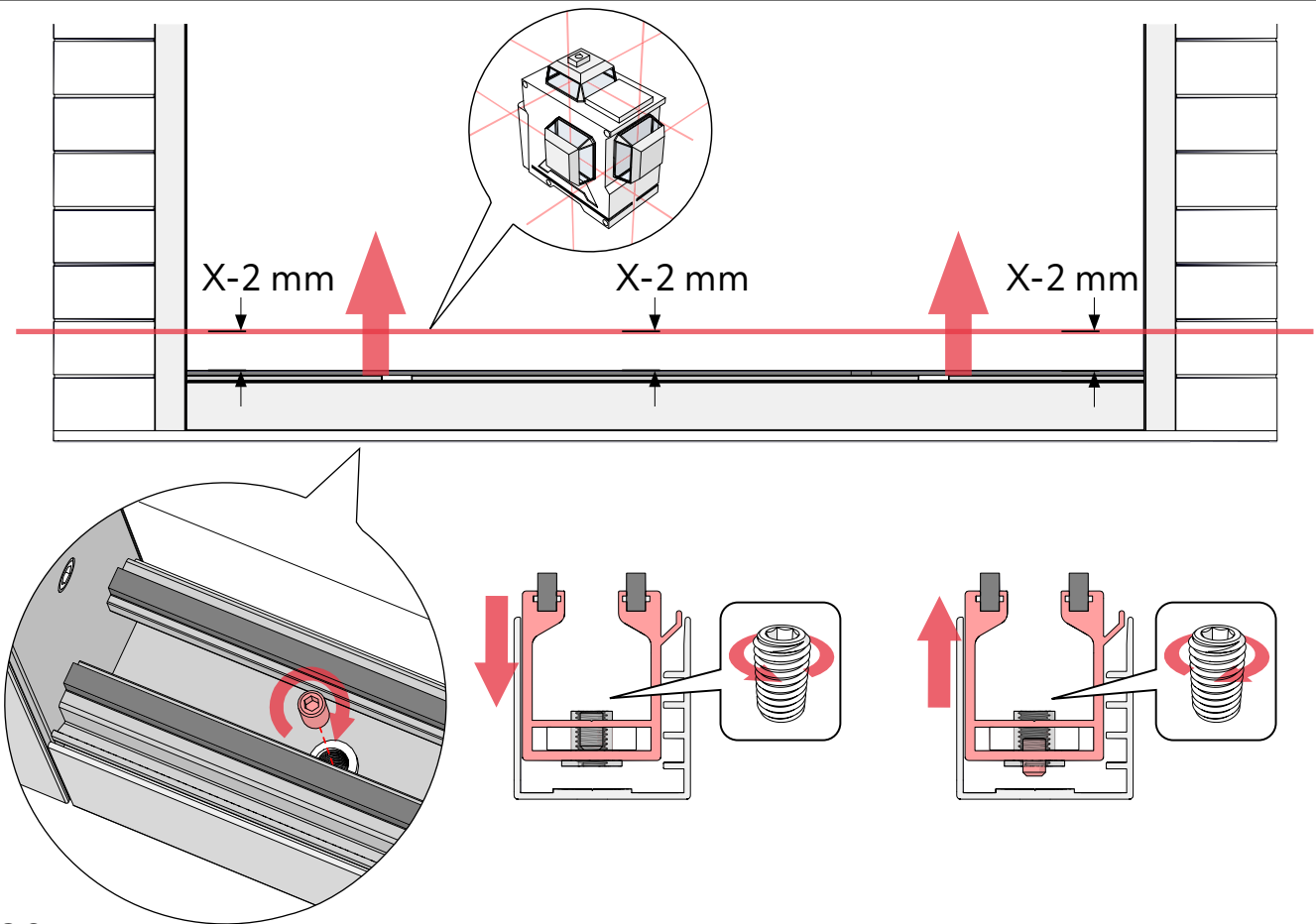

20.

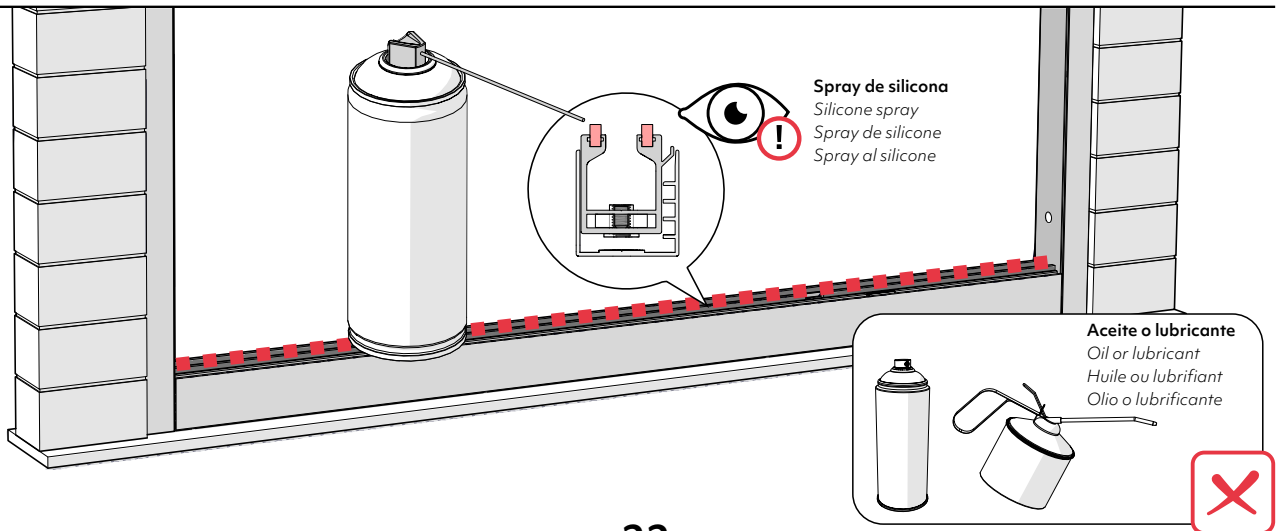

21.

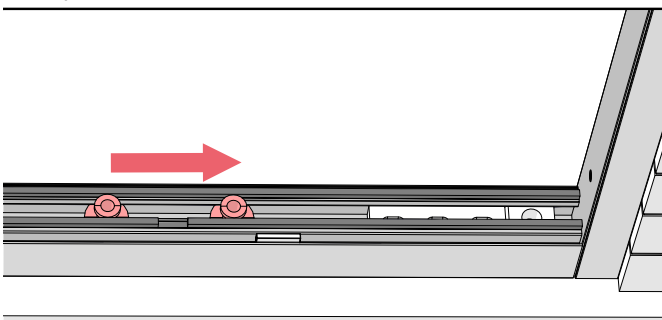

22.

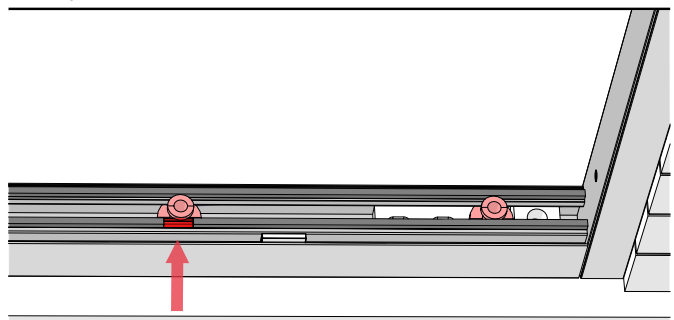

23.

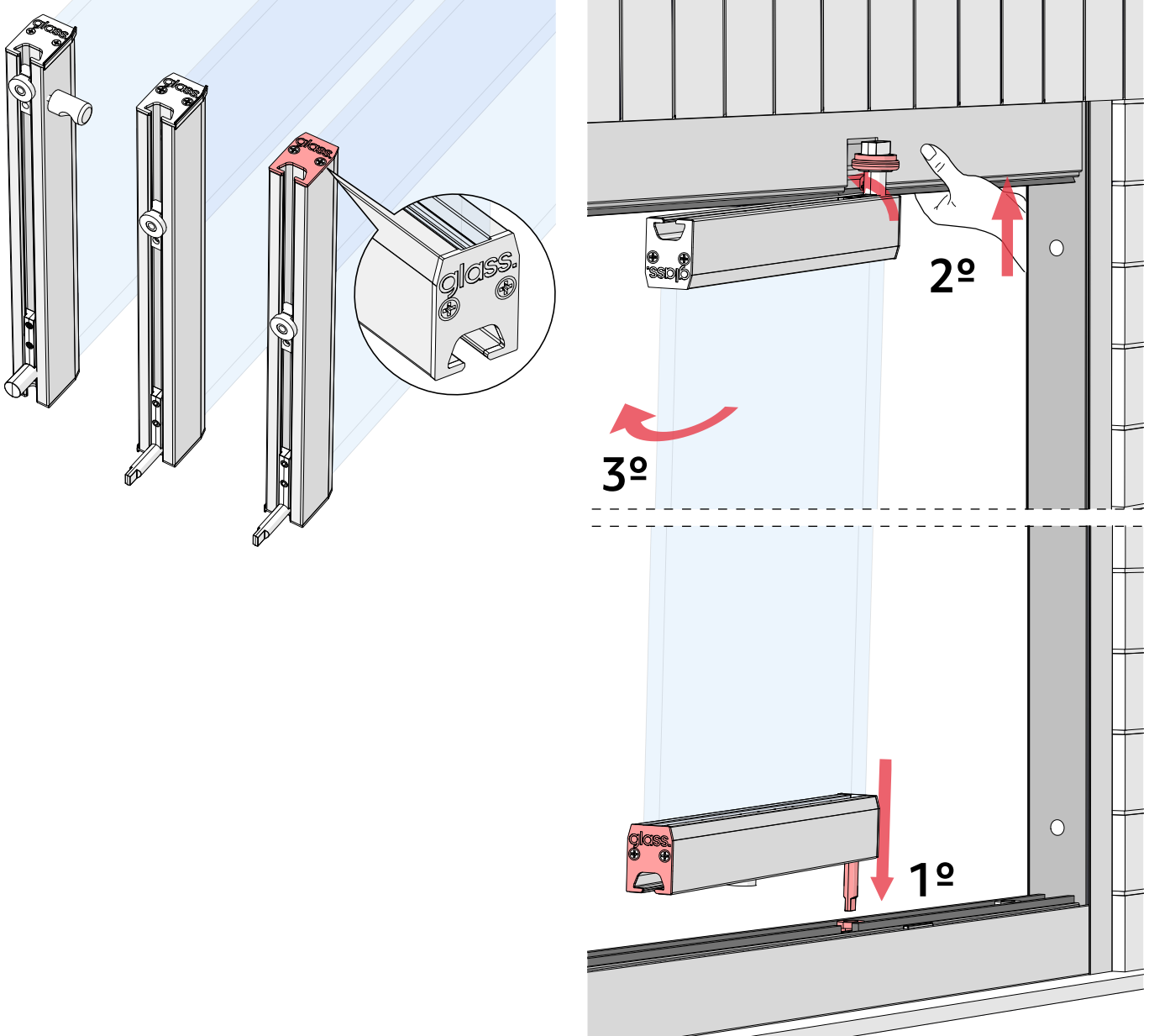

24.

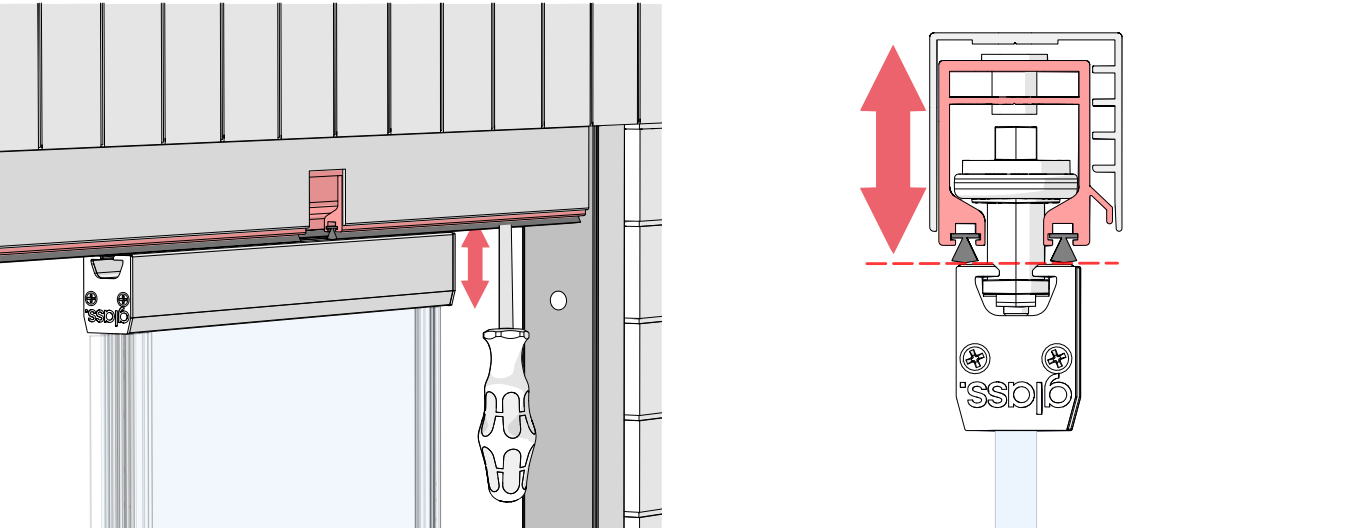

25.

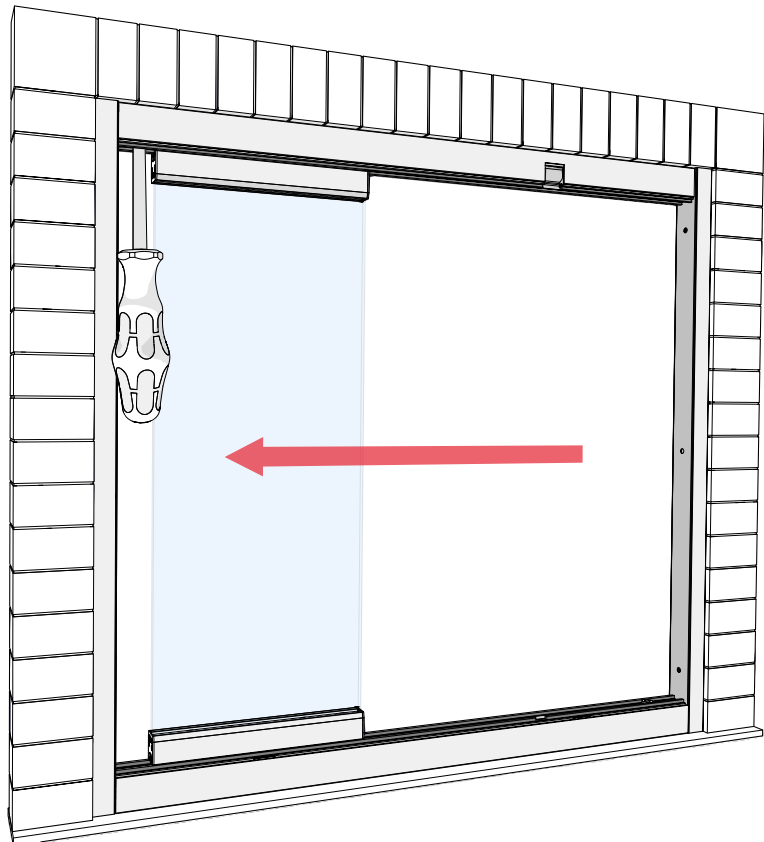
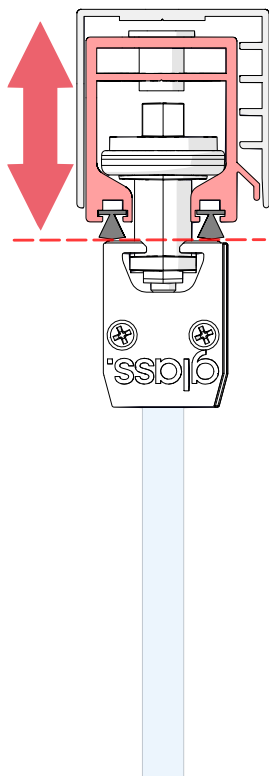

26.

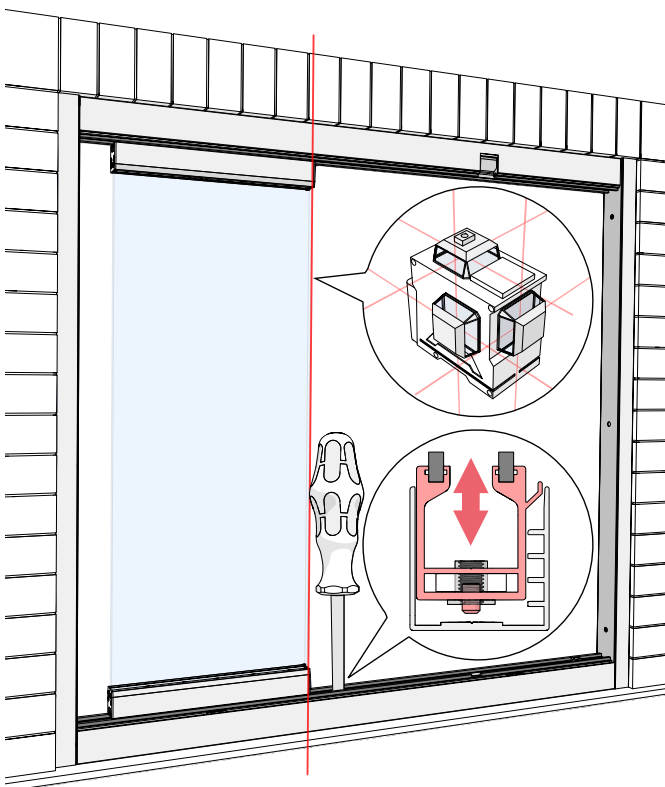

27.

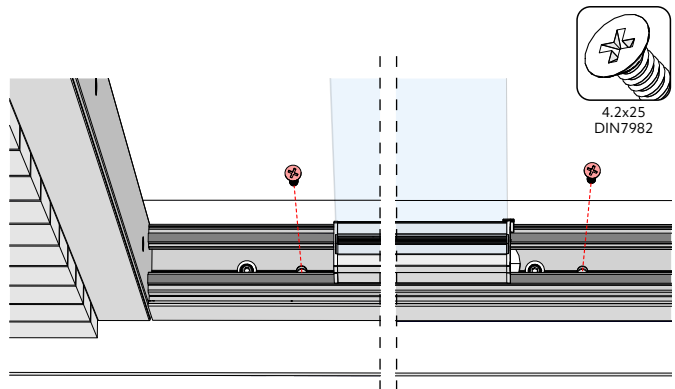

28.

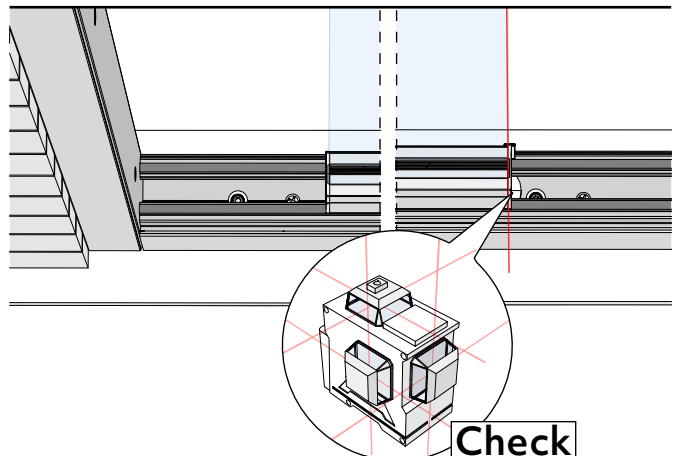

29.

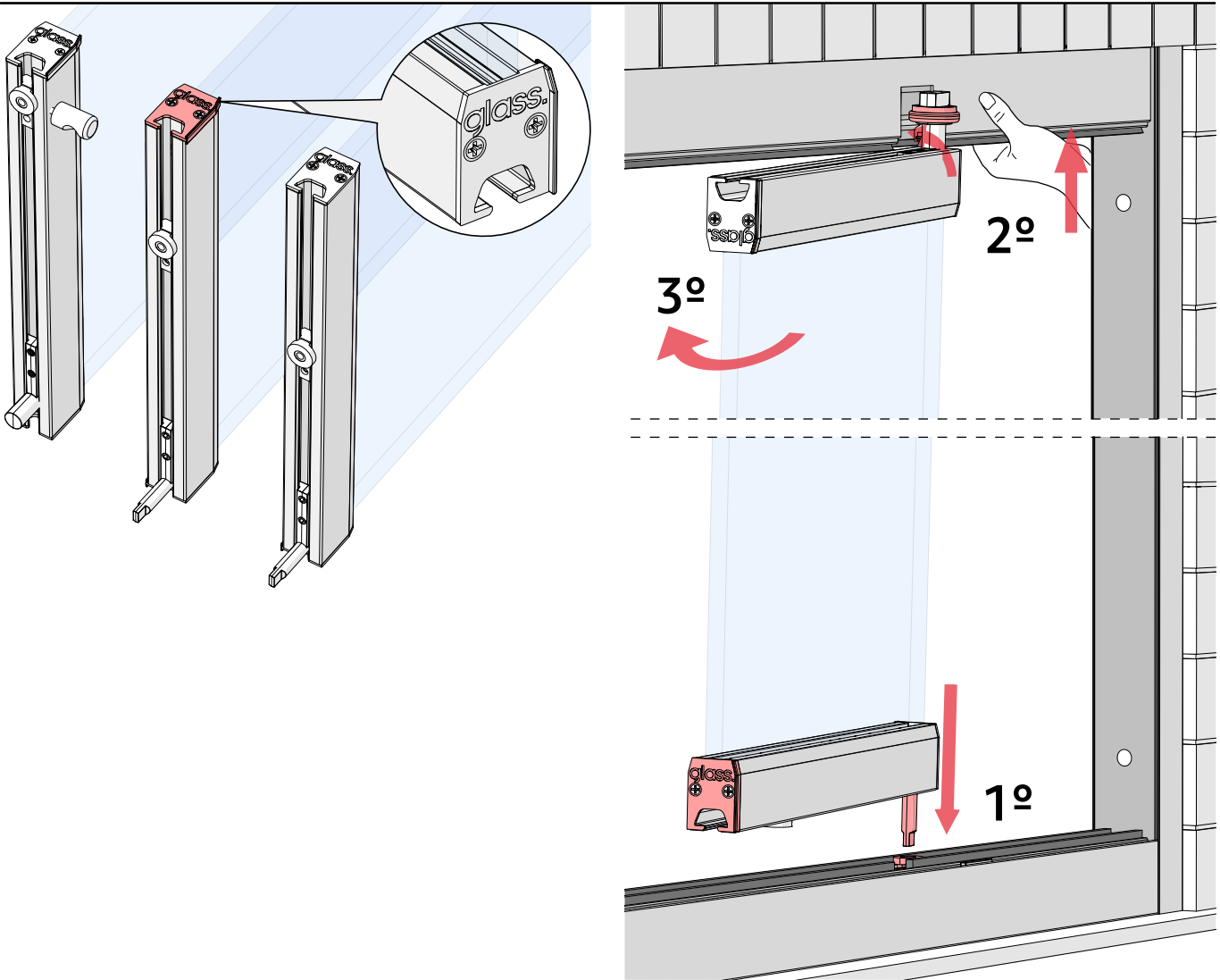

30.

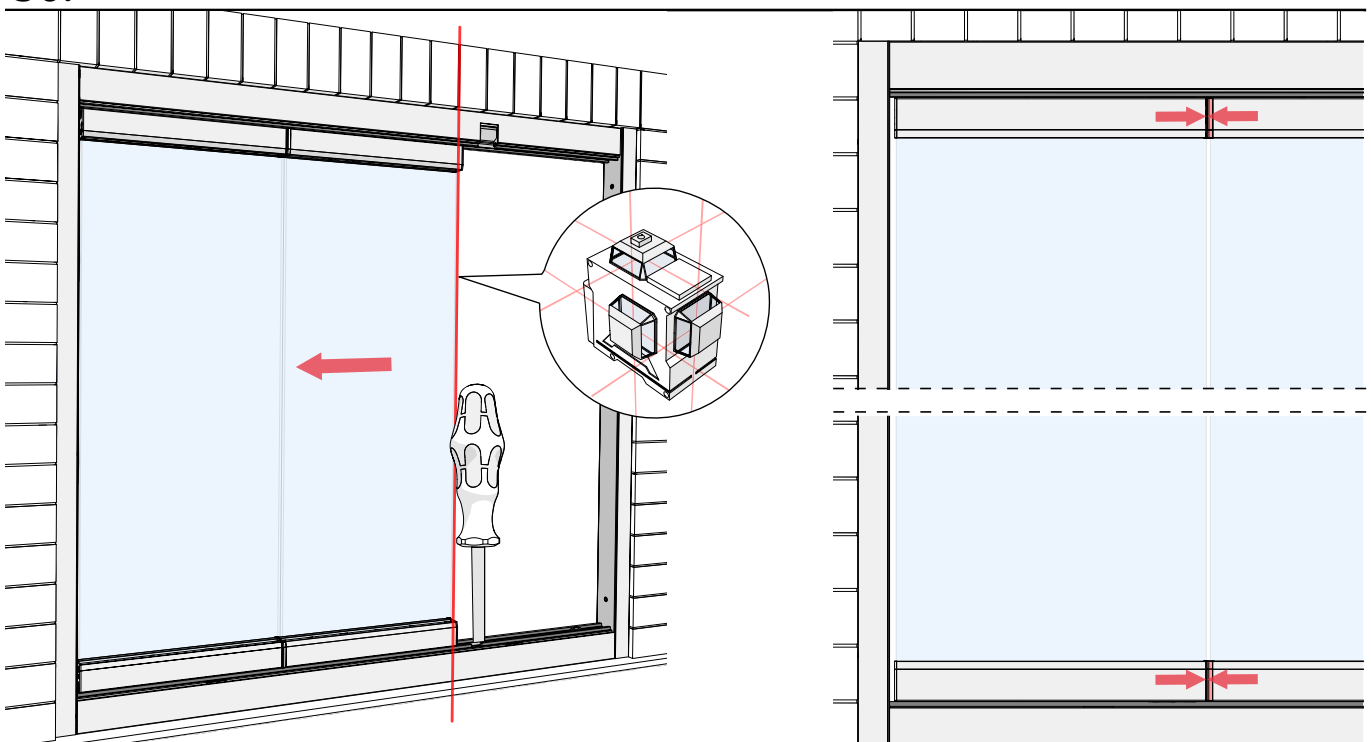

31.

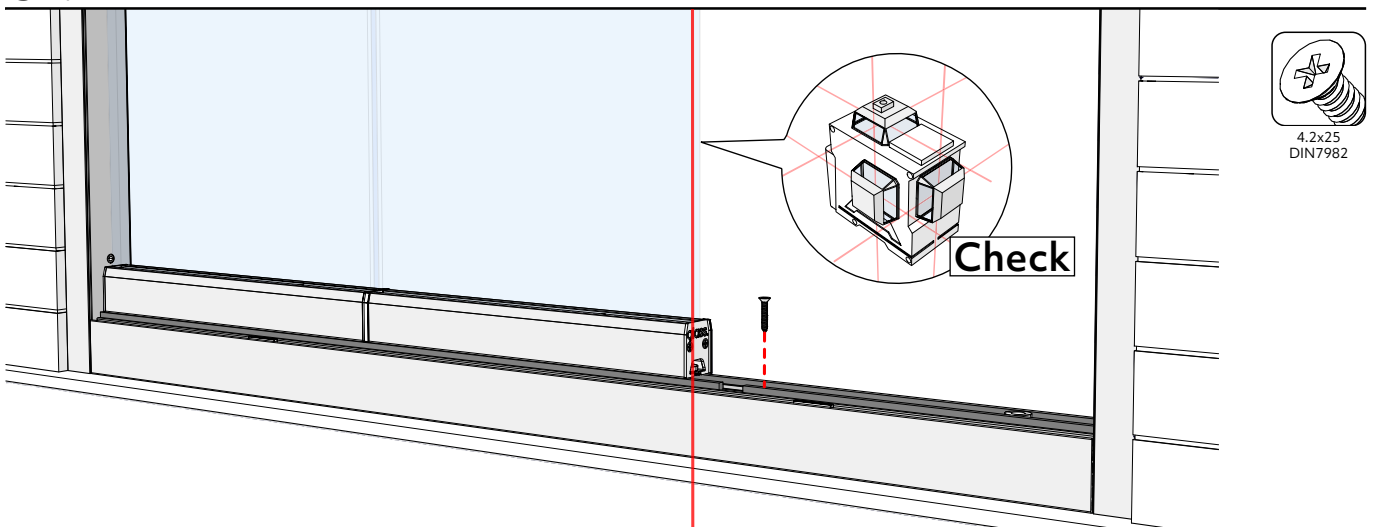

32a.

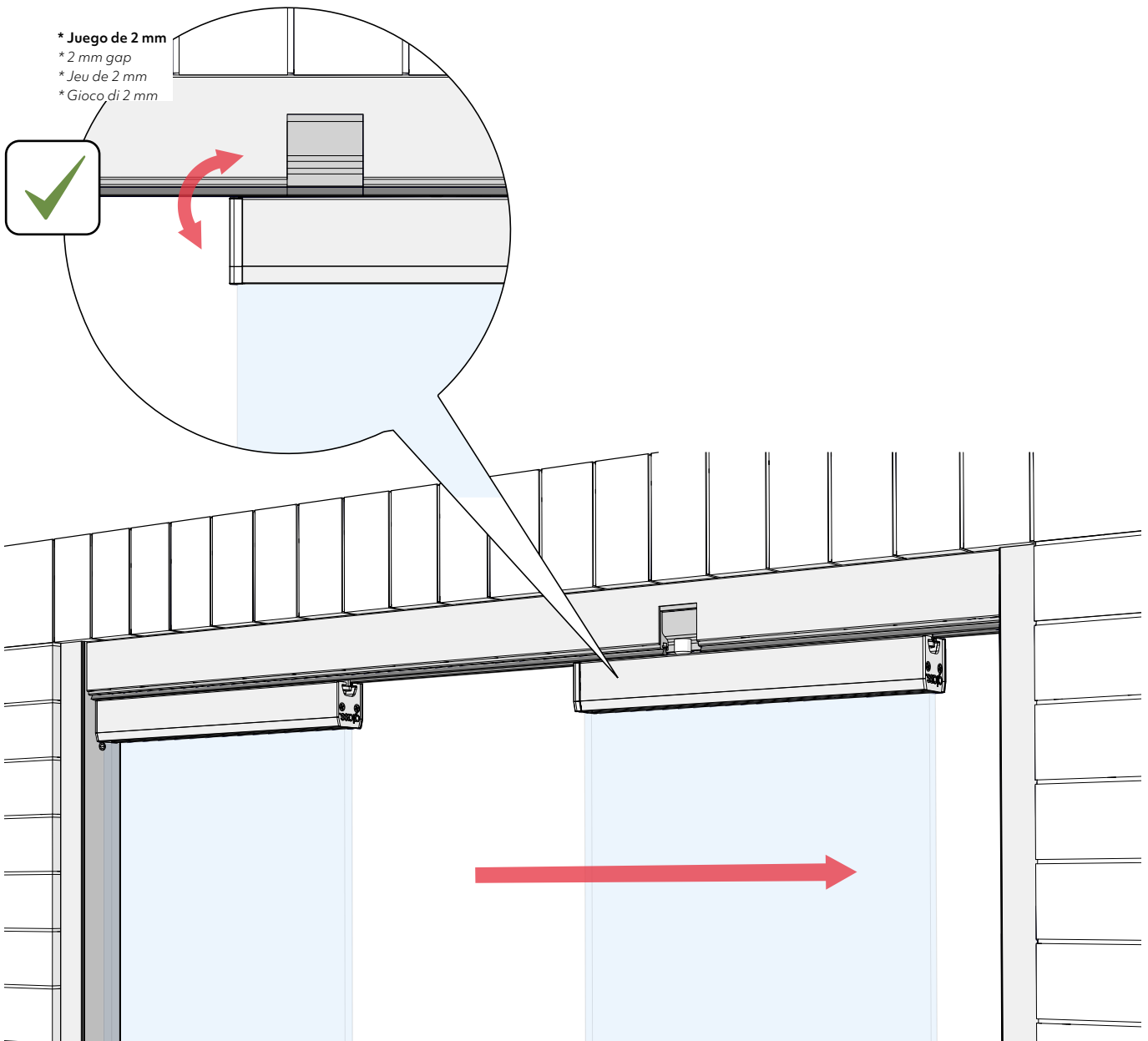

32b.

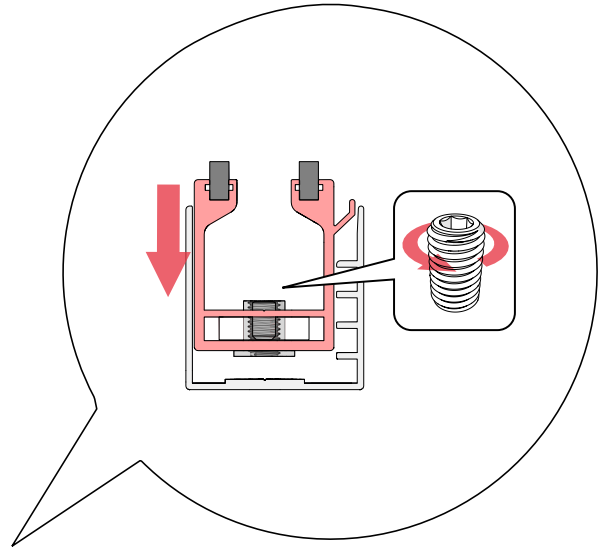
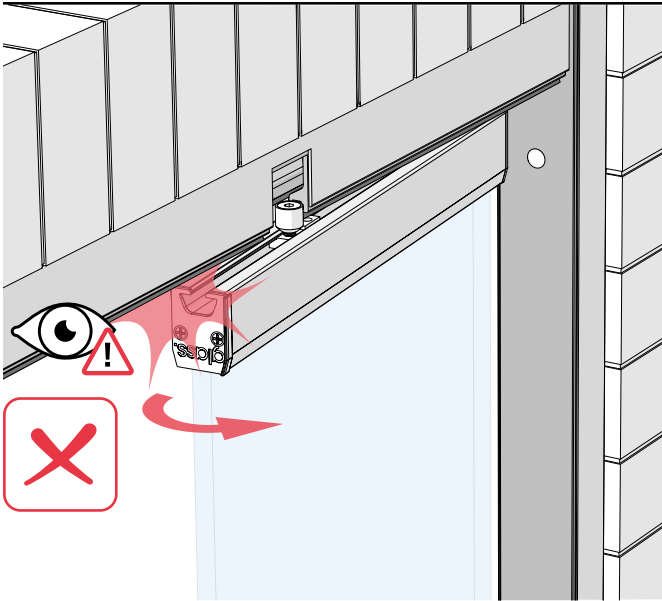

32c.

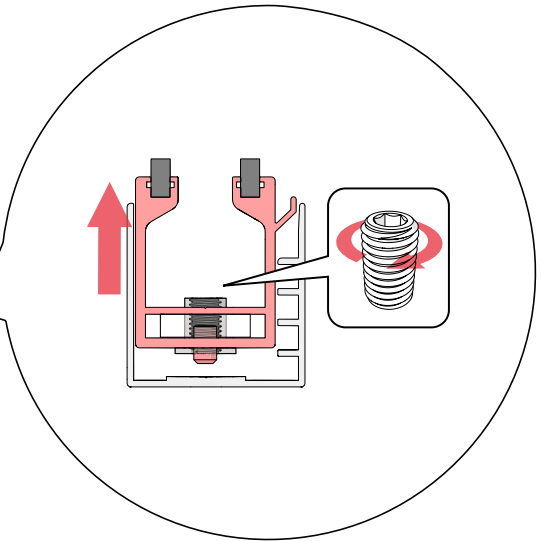
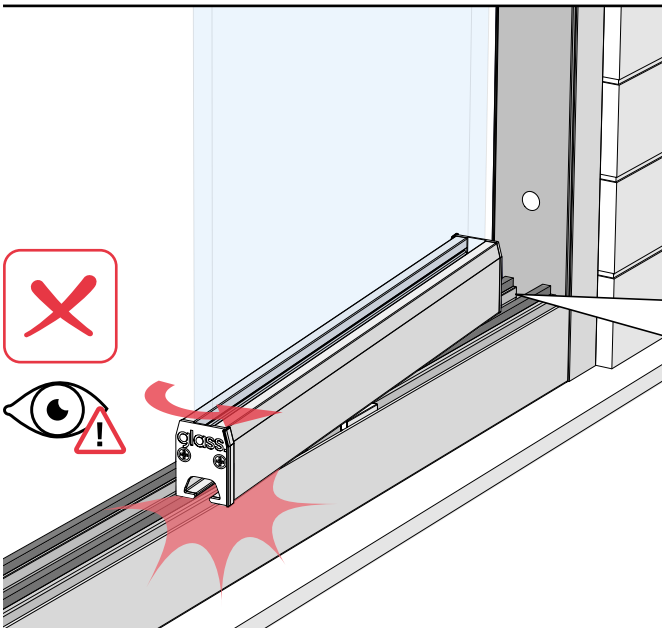

33.

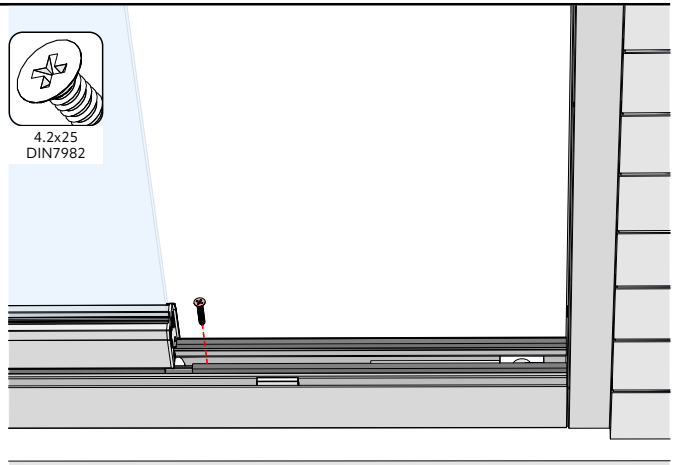
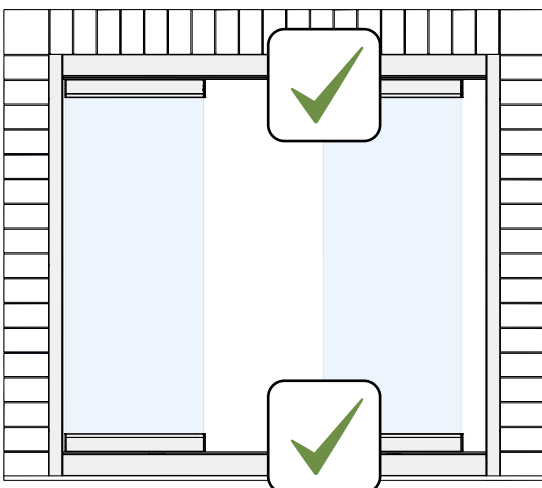

34.

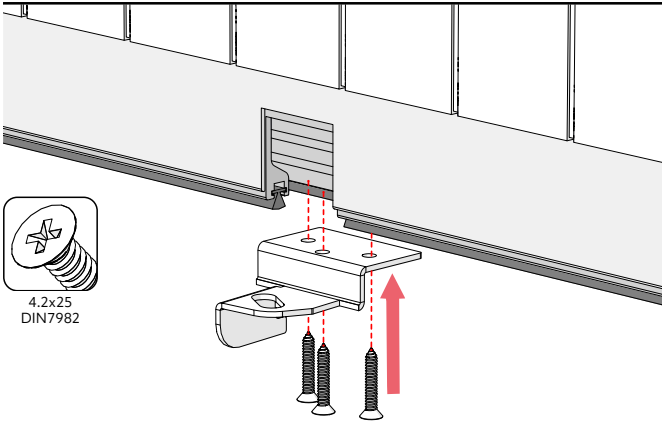

35.

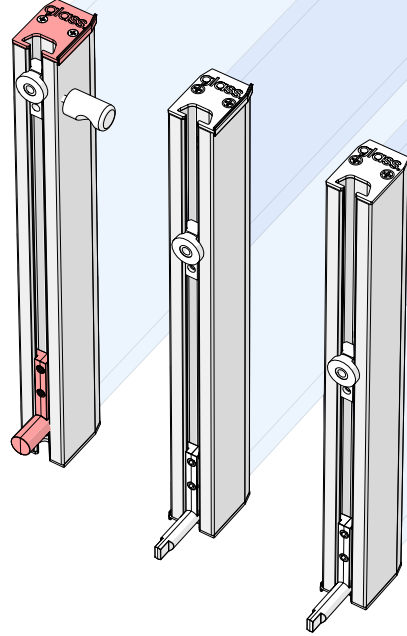

36.

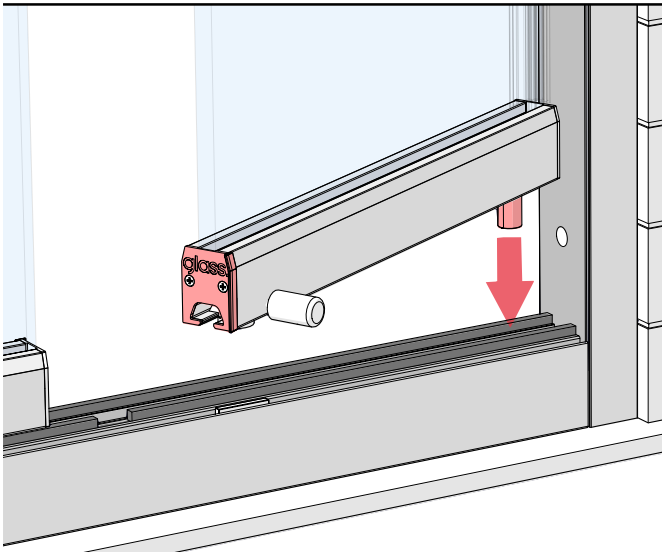

37.

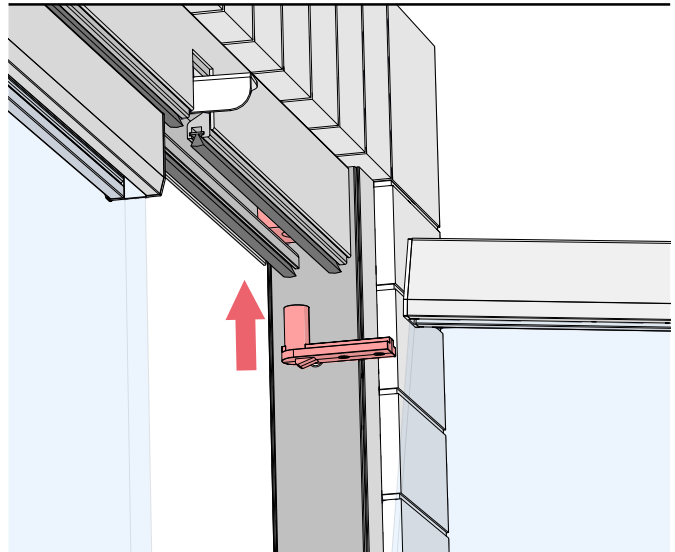

38.

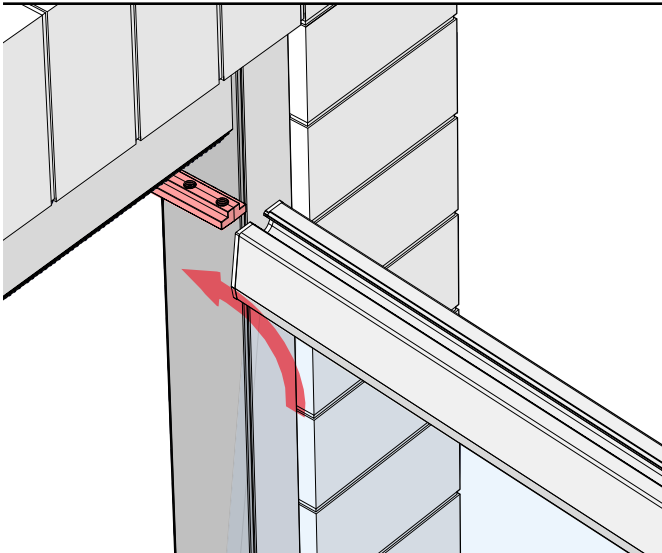

39.

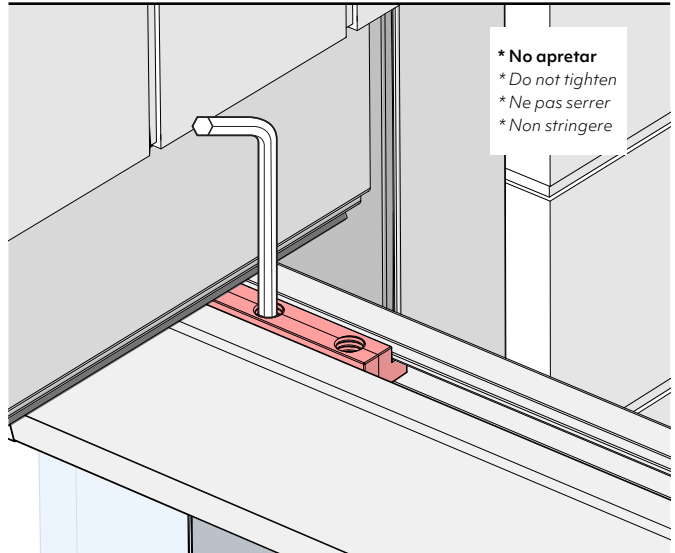

40.

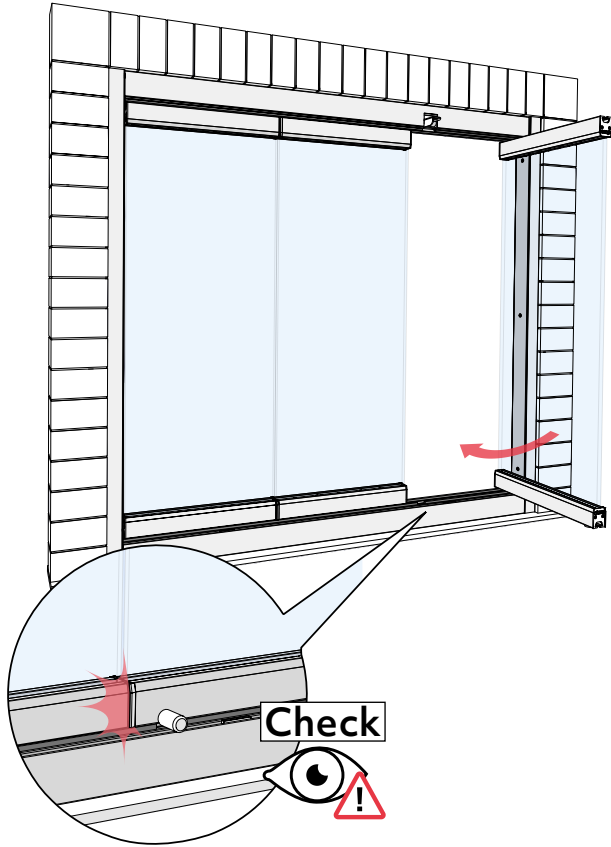

41.

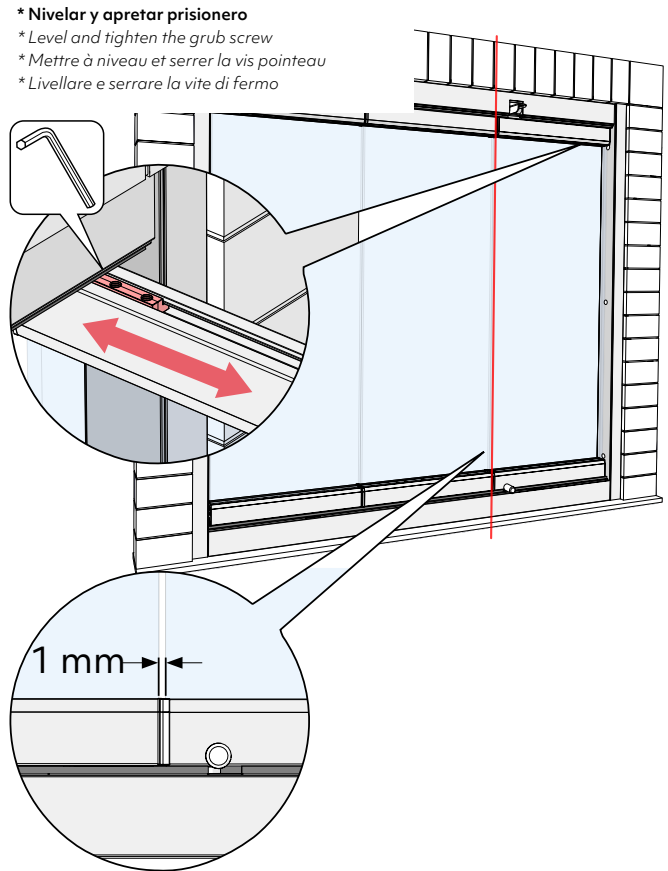

42.

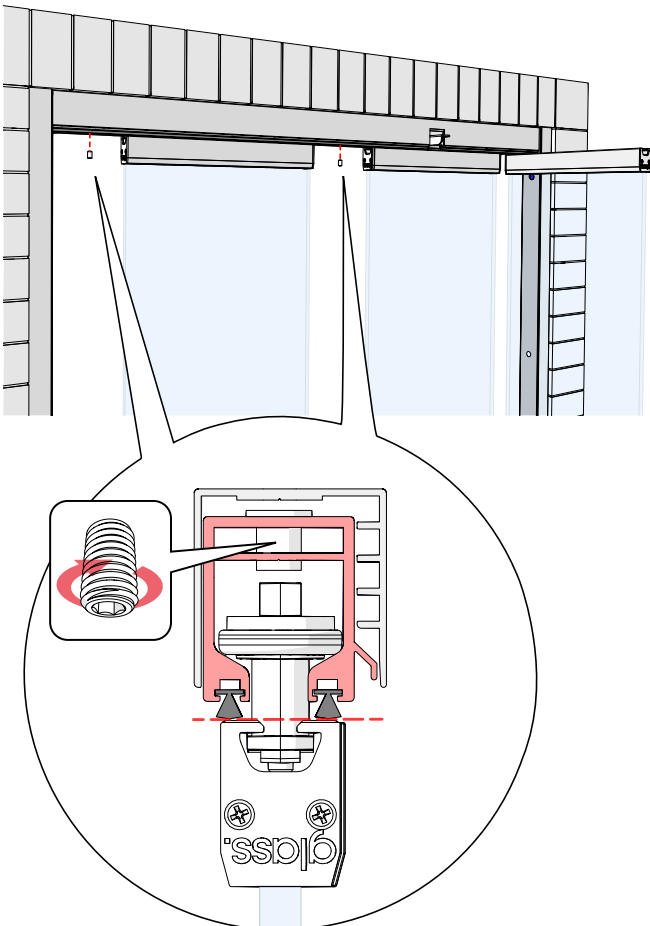

43.

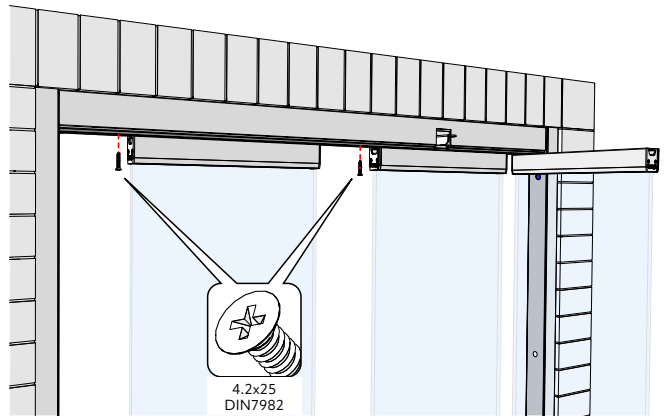

44.

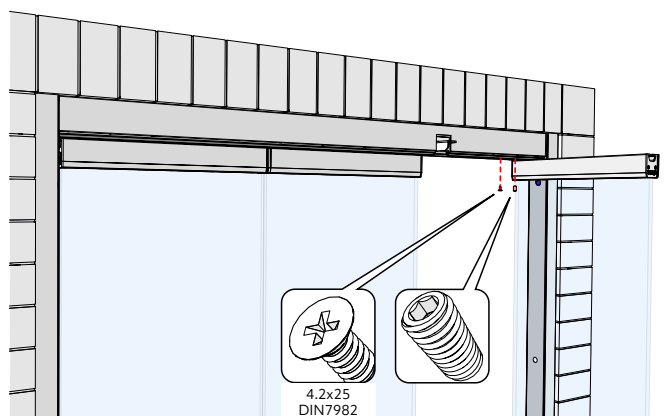

45.

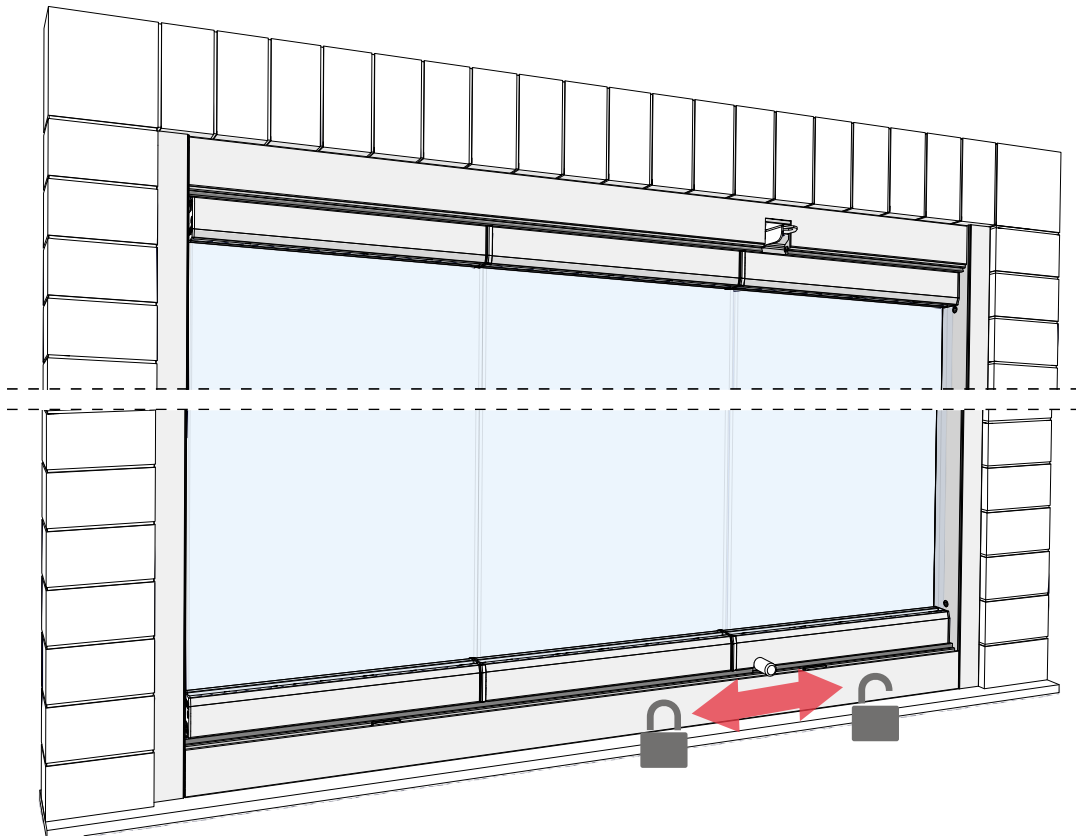

46.

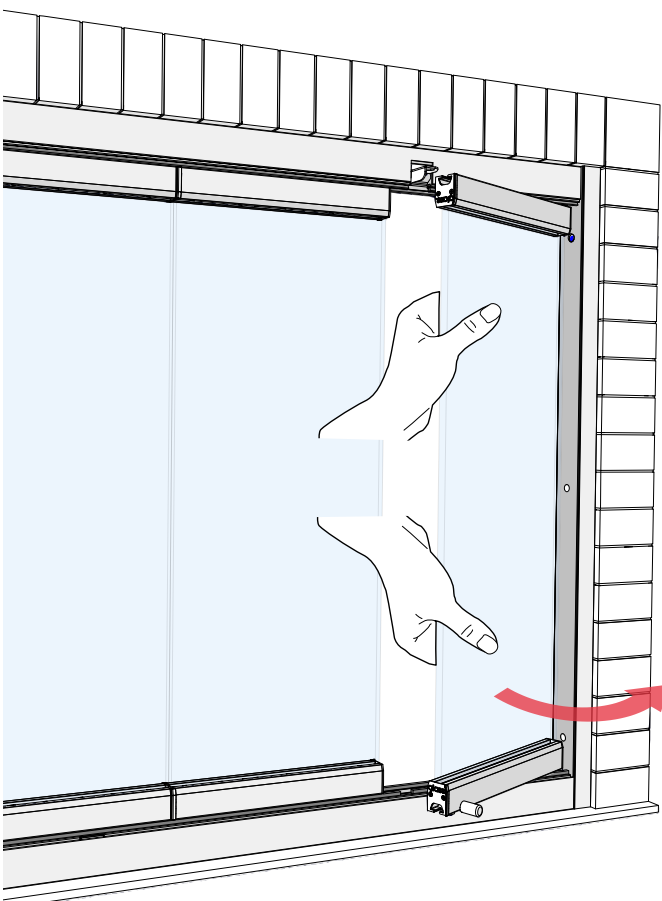

47.

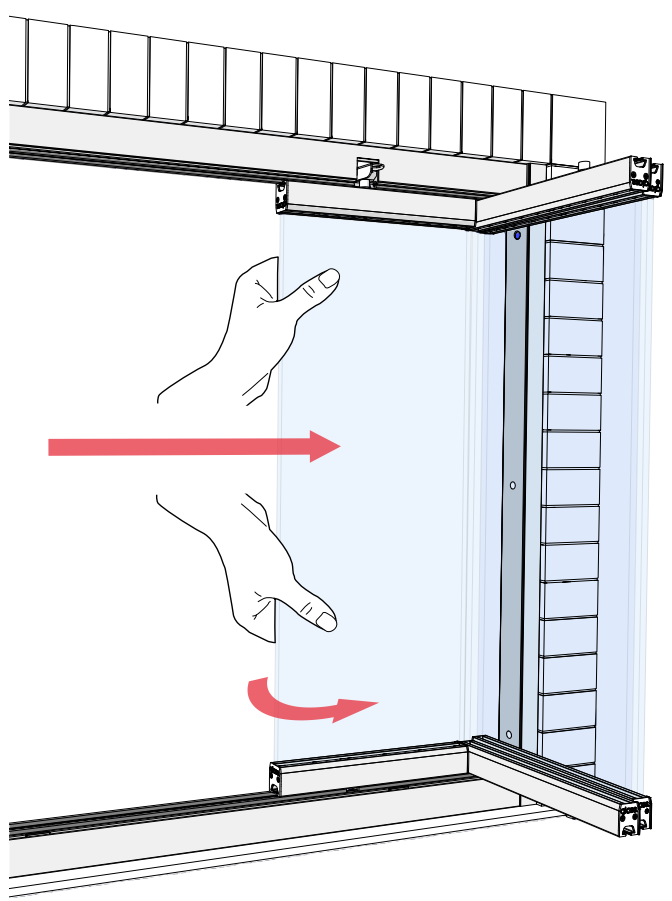

48.

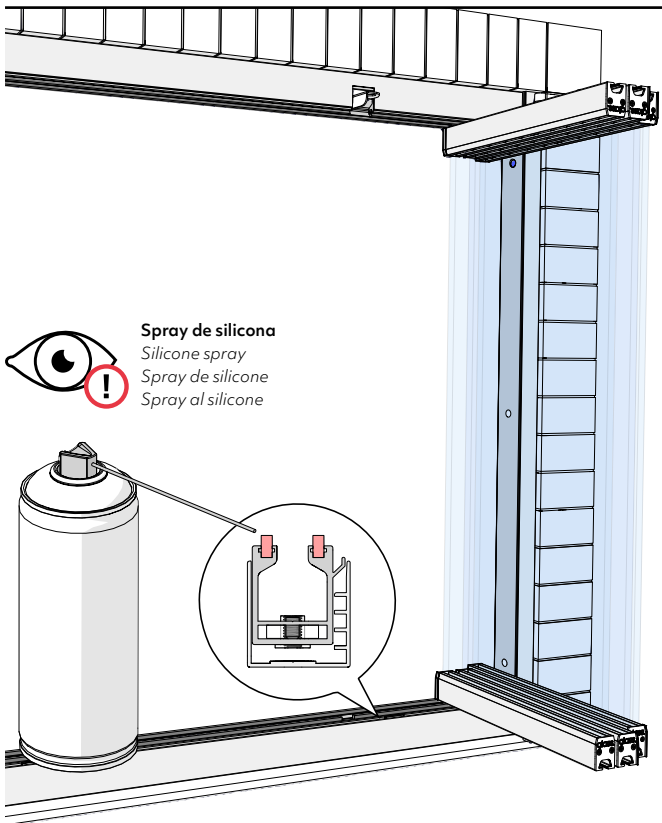

49.

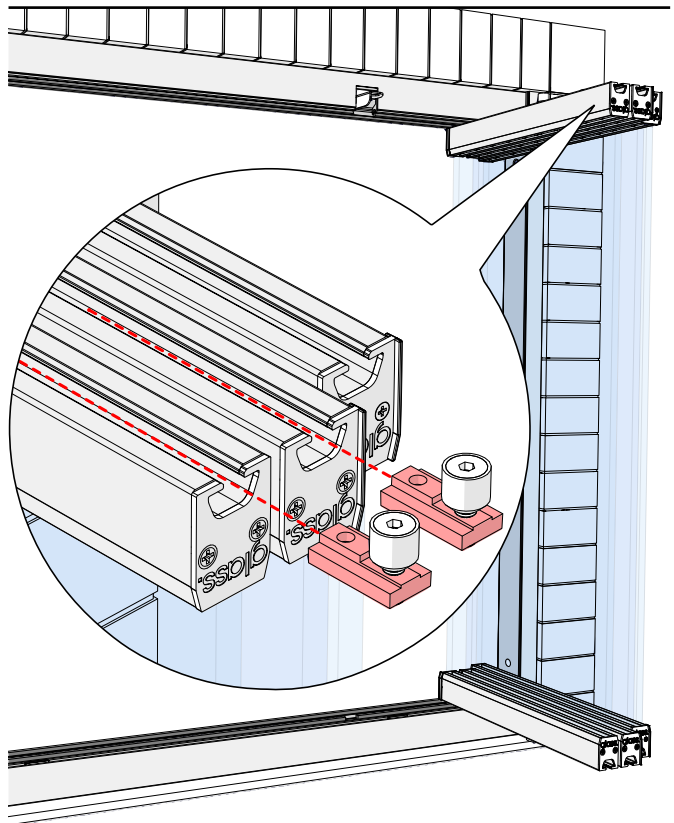

50.

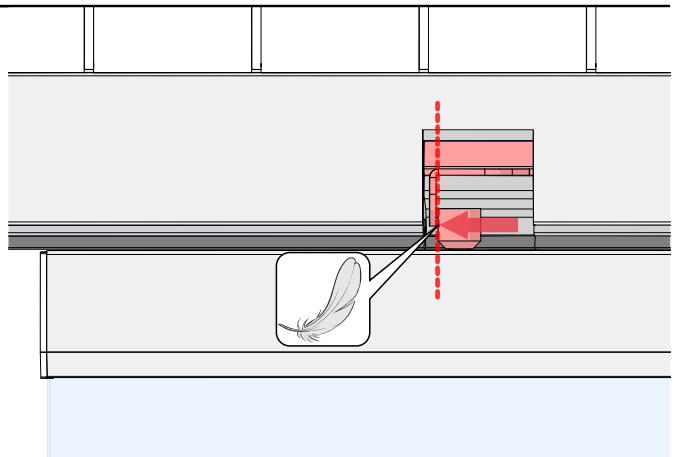
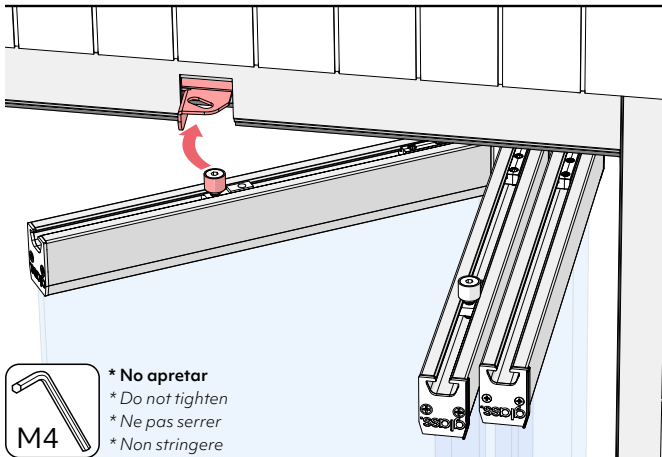

51.

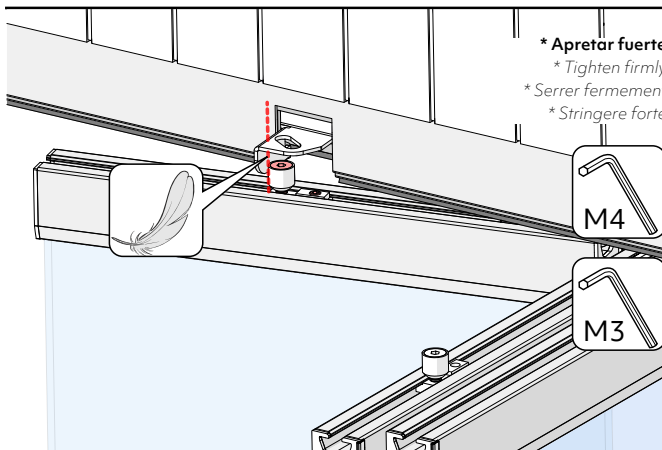

52.

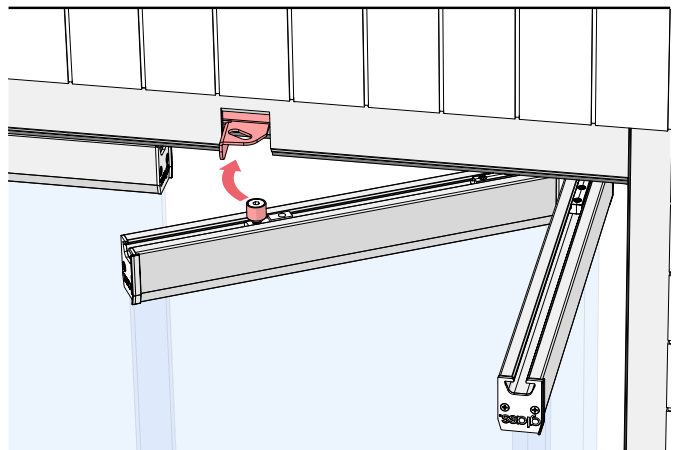

53.

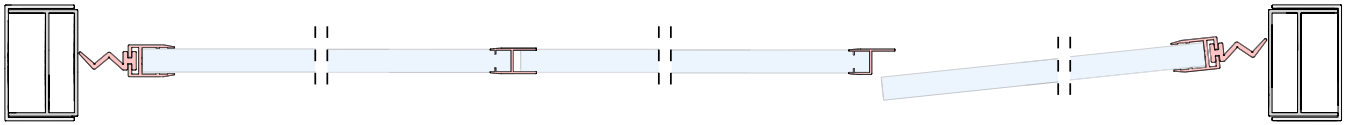

54.

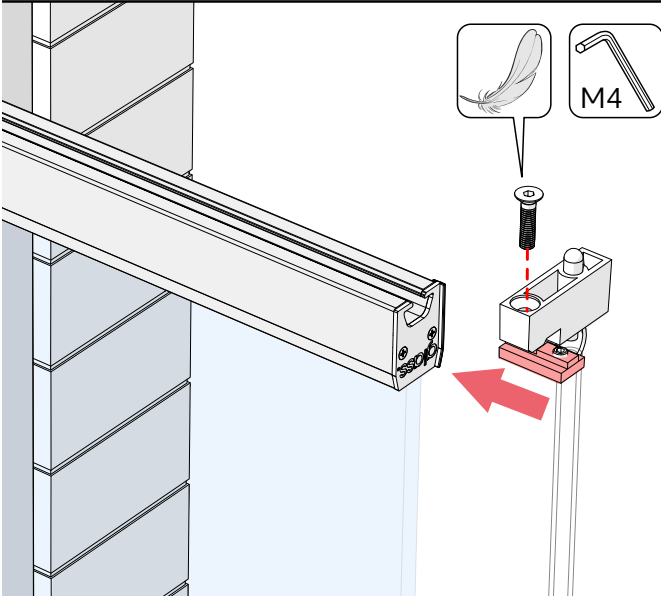

55.

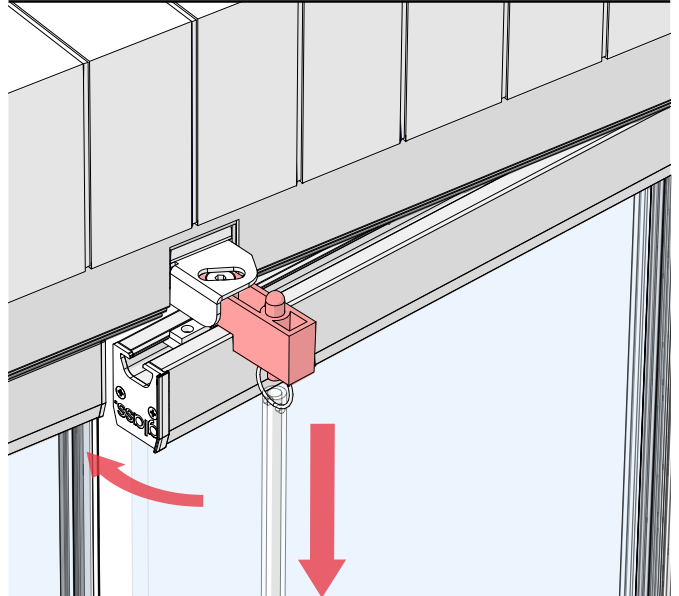

56.

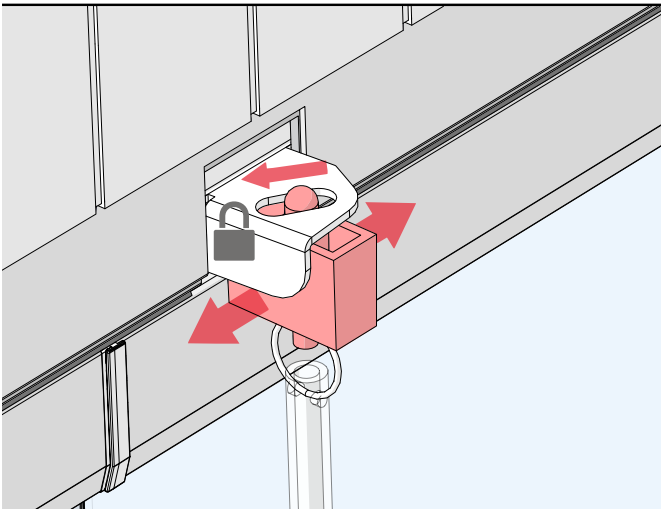

57.

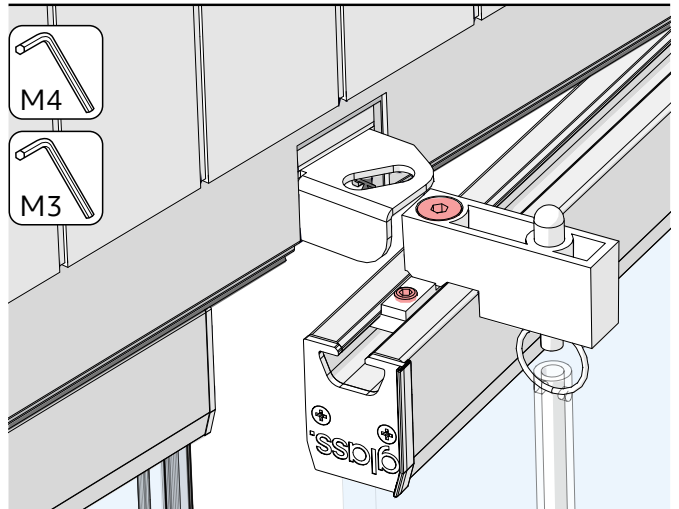

58.

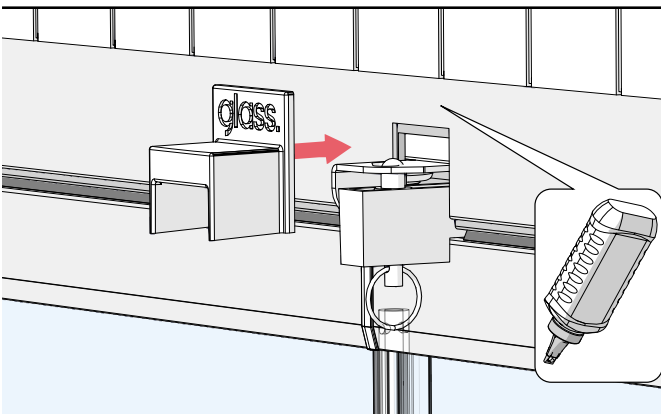

59.

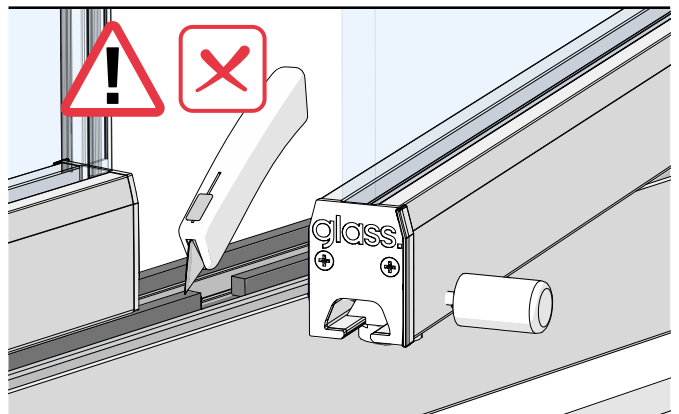

glass.
by gaviota

GLASS

Calle de la Térmica, 4
03638 Salinas (Alicante) - España / Spain
Tel. (+34) 965 357 674 • (+34) 682 024 864
soporte@glassbygaviota.com - hola@glassbygaviota.com
www.glassbygaviota.com